

SERIES F7399 - JIS 5K and 10K

Emergency Shut-Off Valve - Types "A" and "B"

Manufactured in accordance to JIS F7400

Flanges as per JIS B2220 - 5K or 10K

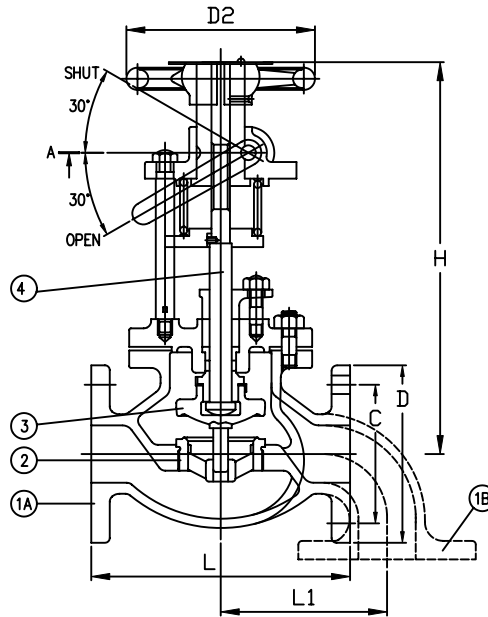

Hydraulic	Body	7kg
Inspection	Seat	2kg

For Sizes 25A & 40A

Part Nr.	Mat	Code
1A - Body	Bronze	BC6
3 - Disc	Bronze	BC6
4 - Stem	Brass	C3771BD

For Sizes 50A & Higher

Part Nr.	Mat	Cod
1B - Body	Cast Steel	SC49
2 - Seat	Stainless Steel	SCS2
3 - Disc	Stainless Steel	SCS2
4 - Stem	Stainless Steel	SUS403

Size	5K Flanged									10K Flanged								
	L	L1	L2	D	C	No.	h	t	L	L1	L2	D	C	No.	h	t	H	D1
25	130	75	60	95	75	4	12	10	130	80	65	125	90	4	19	14	265	120
40	160	100	75	120	95	4	15	12	170	85	80	140	105	4	19	16	310	140
50	210	125	90	130	105	4	15	14	220	125	90	155	120	4	19	16	335	160
65	250	155	100	155	130	4	15	14	270	155	100	175	140	4	19	18	395	180
80	280	165	120	180	145	4	19	18	300	165	120	185	150	8	19	18	420	180
100	340	200	130	200	165	8	19	18	350	200	130	210	175	8	19	18	510	224
125	410	250	160	235	200	8	19	20	420	250	160	250	210	8	19	20	440	250
150	480	300	180	265	230	8	19	22	490	300	180	280	240	8	19	22	520	320