

PN 10-16-25 Cast Steel Gate Valve Stainless Steel Trim

Series 1311 ... OS&Y - PN10
 Series 1312 ... OS&Y - PN16
 Series 1313 ... OS&Y - PN25

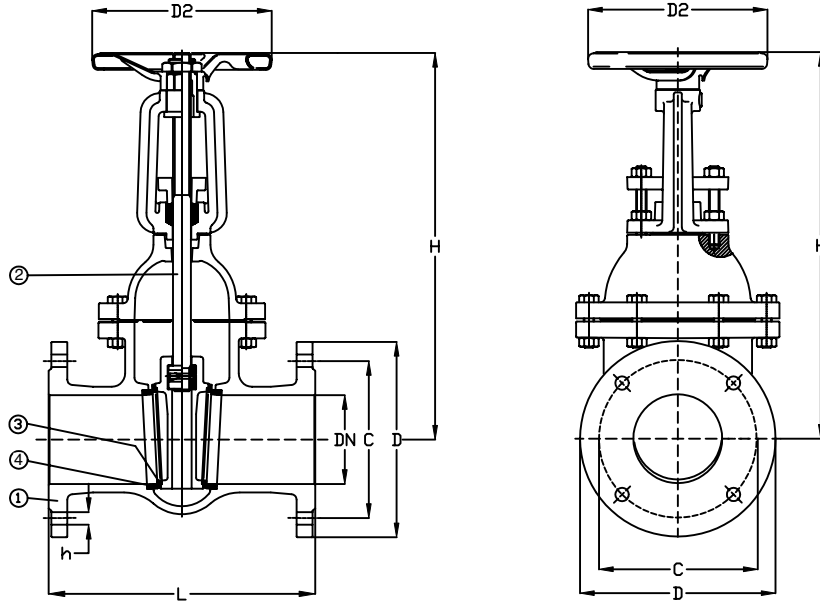

Face to Face according to DIN 3202-F5
 Flanges according to DIN2501-PN10, 16 & 25

Part Nr.	Material	Code
1 - Body	Cast Steel	GSC-25N
2 - Stem	Stainless Steel	AISI 420
3 - Disc	Stainless Steel	AISI 410
4 - Seat	Stainless Steel	AISI 410

Size DN	Nom. Pressure PN	Hydraulic Inspection	
		Body	Seat
40 to 500	25	38	25
40 to 500	16	25	16
40 to 500	10	16	10

Size	L	DIN PN10					DIN PN16					DIN PN25					H	D2	Kg
		D	C	No.	h	t	D	C	No.	h	t	D	C	No.	h	t			
40	240	Same as DIN PN 25					Same as DIN PN 25					150	110	4	18	18	230	160	11
50	250	Same as DIN PN 25					Same as DIN PN 25					165	125	4	18	20	245	160	12
65	270	Same as DIN PN 16					185	145	4	18	18	185	145	8	18	22	290	160	17
80	280	200	160	4	18	22	Same as DIN PN25					200	160	8	18	24	315	160	18
100	300	Same as DIN PN 16					220	180	8	18	20	235	190	8	22	24	355	200	35
125	325	Same as DIN PN 16					250	210	8	18	22	270	220	8	26	26	415	250	35
150	350	Same as DIN PN 16					285	240	8	22	22	300	250	8	26	28	460	250	46
200	400	340	295	8	22	24	340	295	12	22	24	375	320	12	30	34	545	315	75
250	450	395	350	12	22	26	405	355	12	25	26	450	385	12	33	38	635	315	110
300	500	445	400	12	22	26	460	410	12	26	28	515	450	16	33	42	725	400	115
350	550	505	460	16	22	26	520	470	16	26	30	580	510	16	36	46	830	400	242
400	600	565	515	16	26	26	580	525	16	30	32	660	585	16	39	50	945	400	285
500	700	670	620	20	26	28	715	650	20	33	34	775	670	20	42	52	1120	500	410