

# PN 16 Cast Iron Gate Valve Brass Trim

Series 1302 ... OS&Y

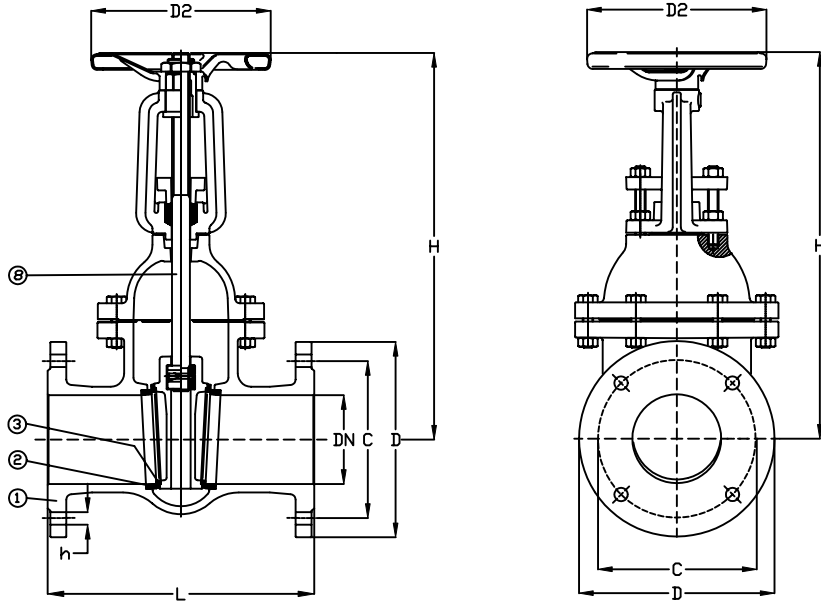

Face to Face according to DIN 3202-F5  
Flanges according to DIN2501-PN16

| Part Nr. | Material  | Code     | Size      | Nom. Pressure |    | Hydraulic Inspection |      |
|----------|-----------|----------|-----------|---------------|----|----------------------|------|
|          |           |          |           | DN            | PN | Body                 | Seat |
| 1 - Body | Cast Iron | GG25     | 40 to 300 | 16            | 25 | 16                   |      |
| 2 - Stem | Brass     | UNI 5035 |           |               |    |                      |      |
| 3 - Disc | Brass     | UNI 5035 |           |               |    |                      |      |
| 4 - Seat | Brass     | UNI 5035 |           |               |    |                      |      |

| Size | L   | D   | C   | No. | h  | t  | D2  | H   | Kg  |
|------|-----|-----|-----|-----|----|----|-----|-----|-----|
| 40   | 240 | 150 | 110 | 4   | 18 | 18 | 140 | 265 | 18  |
| 50   | 250 | 165 | 125 | 4   | 18 | 18 | 140 | 275 | 22  |
| 65   | 270 | 185 | 145 | 4   | 18 | 18 | 160 | 335 | 32  |
| 80   | 280 | 200 | 160 | 8   | 18 | 20 | 160 | 355 | 39  |
| 100  | 300 | 220 | 180 | 8   | 18 | 20 | 180 | 400 | 51  |
| 125  | 325 | 250 | 210 | 8   | 18 | 22 | 200 | 495 | 68  |
| 150  | 350 | 285 | 240 | 8   | 22 | 22 | 200 | 585 | 84  |
| 175  | 375 | 315 | 270 | 8   | 22 | 24 | 280 | 660 | 109 |
| 200  | 400 | 340 | 295 | 12  | 22 | 24 | 280 | 700 | 130 |
| 250  | 450 | 405 | 355 | 12  | 26 | 26 | 280 | 830 | 203 |
| 300  | 500 | 460 | 410 | 12  | 26 | 28 | 325 | 960 | 259 |