

IACS

INTERNATIONAL ASSOCIATION
OF CLASSIFICATION SOCIETIES

Shipbuilding and Repair Quality Standard

© IACS – International Association of Classification Societies, 1996

All rights reserved

Except as permitted under current legislation no part of this work may be photocopied, stored in a retrieval system, published, performed in public, adapted, broadcast, transmitted, recorded or reproduced in any form or by any means, without prior permission of the copyright owner.

Where IACS has granted written permission for any part of this publication to be quoted such quotation must include acknowledgement to IACS.

Enquiries should be addressed to The Permanent Secretary,
International Association of Classification Societies,
5 Old Queen Street,
London, SW1H 9JA
United Kingdom
Telephone: +44-171-976 0660
Telefax: +44-171-976 0440
Internet: permsec@iacs.org.uk

Terms and Conditions

"The International Association of Classification Societies (IACS), its Member Societies and their officers, members, employees and agents (on behalf of whom this notice is issued) shall be under no liability or responsibility in negligence or otherwise howsoever to any person in respect of any information or advice expressly or impliedly given in this document, or in respect of any inaccuracy herein or omission herefrom or in respect of any act or omission which has caused or contributed to this document being issued with the information or advice it contains (if any).

Without derogating from the generality of the foregoing, neither IACS nor its Member Societies and their officers, members, employees or agents shall be liable in negligence or otherwise howsoever for any indirect or consequential loss to any person caused by or arising from any information, advice, inaccuracy or omission being given or contained herein or any act or omission causing or contributing to any such information, advice, inaccuracy or omission being given or contained herein."

Part A Shipbuilding and
Repair Quality Standard for
New Construction

Part B Repair Quality Standard
for Existing Ships

Part A Shipbuilding and Repair Quality Standard for New Construction

PART A - SHIPBUILDING AND REPAIR QUALITY STANDARDS FOR NEW CONSTRUCTION

1. Scope

2. General requirements for new construction

3. Qualification of personnel and procedures

3.1 Qualification of welders

3.2 Approval of welding procedures

3.3 Qualification of NDE operators

4. Materials

4.1 Materials for structural members

4.2 Under thickness tolerances

4.3 Surface conditions

5. Cutting

5.1 Gas cutting

5.2 Plasma arc cutting

5.3 Laser beam cutting

6. Fabrication and fairness

6.1 Flange longitudinals and flange brackets

6.2 Built-up sections

6.3 Corrugated bulkheads

6.4 Pillars, brackets and stiffeners

6.5 Maximum heating temperature on surface for line heating

6.6 Block assembly

6.7 Special sub-assembly

6.8 Shape

6.9 Fairness of plating between frames

6.10 Fairness of plating with frames

7. Alignment

8. Welding

8.1 Typical butt weld plate edge preparation (manual welding)

8.2 Typical fillet weld plate edge preparation (manual welding)

8.3 Typical butt and fillet weld profile (manual welding)

8.4 Lap, plug and slot welding

8.5 Distance between welds

8.6 Automatic welding

9. Repair

9.1 Typical misalignment repair

9.2 Typical butt weld plate edge preparation repair (manual welding)

9.3 Typical fillet weld plate edge preparation repair (manual welding)

9.4 Typical fillet and butt weld profile repair (manual welding)

9.5 Distance between welds repair

9.6 Erroneous hole repair

9.7 Repair by insert plate

9.8 Weld surface repair

REFERENCES

1. IACS "Bulk Carriers - Guidelines for Surveys, Assessment and Repair of Hull Structure"
2. TSCF "Guidelines for the inspection and maintenance of double hull tanker structures"
3. TSCF "Guidance manual for the inspection and condition assessment of tanker structures"
4. IACS UR W7 "Hull and machinery steel forgings"
5. IACS UR W8 "Hull and machinery steel castings"
6. IACS UR W11 "Normal and higher strength hull structural steel"
7. IACS UR W13 "Allowable under thickness tolerances of steel plates and wide flats"
8. IACS UR W14 "Steel plates and wide flats with improved through thickness properties"
9. IACS UR W17 "Approval of consumables for welding normal and higher strength hull structural steels"
10. IACS UR Z10.1 "Hull surveys of oil tankers" and Z10.2 "Hull surveys of bulk carriers" Annex I
11. IACS Recommendation No. 12 "Guidelines for surface finish of hot rolled plates and wide flats"
13. IACS Recommendation No. 20 "Guide for inspection of ship hull welds"

1. Scope

1.1 This standard provides guidance on shipbuilding quality standards for the hull structure during new construction and the repair standard where the quality standard is not met.

Whereas the standard generally applies to

- conventional ship types,
- parts of hull covered by the rules of the Classification Society,
- hull structures constructed from normal and higher strength hull structural steel,

the applicability of the standard is in each case to be agreed upon by the Classification Society.

The standard does generally not apply to the new construction of

- special types of ships as e.g. gas tankers
- structures fabricated from stainless steel or other, special types or grades of steel

1.2 The standard covers typical construction methods and gives guidance on quality standards for the most important aspects of such construction. Unless explicitly stated elsewhere in the standard, the level of workmanship reflected herein will in principle be acceptable for primary and secondary structure of conventional designs. A more stringent standard may however be required for critical and highly stressed areas of the hull, and this is to be agreed with the Classification Society in each case. In assessing the criticality of hull structure and structural components, reference is made to ref. 1, 2 and 3.

1.3 Details relevant to structures or fabrication procedures not covered by this standard are to be approved by the Classification Society on the basis of procedure qualifications and/or recognised national standards.

1.4 It is intended that these standards provide guidance where established shipbuilding or national standards approved by the Classification Society do not exist.

1.5 For use of this standard, fabrication fit-ups, deflections and similar quality attributes are intended to be uniformly distributed about the nominal values. The shipyard is to take corrective action to improve work processes that produce measurements where a skewed distribution is evident. Relying upon remedial steps that truncate a skewed distribution of the quality attribute is unacceptable.

2. General requirements for new construction

2.1 In general, the work is to be carried out in accordance with the Classification Society Rules and under the supervision of the Surveyor to the Classification Society

2.2 Provisions are to be made for proper accessibility, staging, lighting and ventilation. Welding operations are to be carried out under shelter from rain, snow and wind.

2.3 Welding of hull structures is to be carried out by qualified welders, according to approved and qualified welding procedures and with welding consumables approved by the Classification Society, see Section 3. Welding operations are to be carried out under proper supervision by the shipbuilder.

3. Qualification of personnel and procedures

3.1 Qualification of welders

3.1.1 Welders are to be qualified in accordance with the procedures of the Classification Society or to a recognised national or international standard, e.g. EN 287, ISO 9606, ASME Section IX, ANSI/AWS D1.1. Recognition of other standards is subject to submission to the Classification Society for evaluation. Subcontractors are to keep records of welders qualification and, when required, furnish valid approval test certificates.

3.1.2 Welding operators using fully mechanised or fully automatic processes need generally not pass approval testing provided that the production welds made by the operators are of the required quality. However, operators are to receive adequate training in setting or programming and operating the equipment. Records of training and production test results shall be maintained on individual operator's files and records, and be made available to the Classification Society for inspection when requested.

3.2 Qualification of welding procedures

Welding procedures are to be qualified in accordance with the procedures of the Classification Society or a recognised national or international standard, e.g. EN288, ISO 9956, ASME Section IX, ANSI/AWS D1.1. Recognition of other standards is subject to submission to the Classification Society for evaluation. The welding procedure should be supported by a welding procedure qualification record. The specification is to include the welding process, types of electrodes, weld shape, edge preparation, welding techniques and positions.

3.3 Qualification of NDE operators

3.3.1 Personnel performing non-destructive examination for the purpose of assessing quality of welds in connection with new construction covered by this standard, are to be qualified in accordance with Classification Society rules or to a recognised international or national qualification scheme. Records of operators and their current certificates are to be kept and made available to the Surveyor for inspection.

4. Materials

4.1 Materials for Structural Members

All materials, including weld consummables, to be used for the structural members are to be approved by the Classification Society as per the approved construction drawings and meet the respective IACS Unified Requirements. Additional recommendations are contained in the following paragraphs.

All materials used should be manufactured at a works approved by the Classification Society for the type and grade supplied.

4.2 Under Thickness Tolerances

The maximum permissible under thickness tolerance, for hull structural plates and wide flats with thicknesses of 5mm and over, for both normal and high strength steels, is -0.3mm. The thickness is to be measured at random locations whose distance from an edge shall be at least 10mm. Local surface depressions resulting from imperfections and ground areas resulting from the elimination of defects may be disregarded provided the imperfections or grinding are in accordance with the requirements of Section 4.3 "Surface Conditions".

4.3 Surface Conditions

4.3.1 Definitions

Minor Imperfections:	pittings, rolled-in scale, indentations, roll marks, scratches and grooves
Defects:	Cracks, shells, sand patches, sharp edged seams and minor imperfections not exceeding the limits of table 1 in case that the sum of the influenced area exceeds 5% of the total surface in question
Depth of Imperfections or defects:	the depth is to be measured from the surface of the product

4.3.2 Unrepaired Conditions

Minor imperfections, in accordance with the limits described in Table 1, are permissible and may be left unrepaired.

4.3.3 Repairs of Defects

Defects are to be repaired by grinding or welding irrespective of their size and number. Repair by grinding may be carried out over the entire surface up to a depth equal to the under thickness tolerances given in para.4.2.

The sum of the repairs by welding and of the repairs by grinding, reducing the nominal thickness by more than 0.3mm, shall not exceed 2% of the total surface in question.

4.3.4 Repairs by Grinding

For ground areas with a thickness less than the minimum permissible thickness stated in para.4.2, the nominal thickness is not to be reduced by more than 7% or 3mm, whichever is the lesser. Each single ground area is not to exceed 0.25m².

The defects are to be completely removed by grinding. Complete elimination of the defects is to be verified by a magnetic particle or dye penetrant test procedure. The ground areas must have smooth transitions to the surrounding surface.

4.3.5 Repairs by welding

Local defects, which cannot be repaired by grinding, may be repaired by chipping and/or grinding followed by welding in accordance with the qualified procedures approved by the Classification Society concerned.

Any single welded area is not to exceed 0.125m². The weld preparation should not reduce the thickness of the product below 80% of the nominal thickness. Welding is to be completed with one layer of weld bead in excess, which is subsequently to be ground smooth, level with the plate surface. The soundness of the repair is to be verified by ultrasonic, magnetic particle or dye penetrant methods.

Plate Thickness	Surface Area	100%	15%	5%	2%
$3 \leq t < 8\text{mm}$	N + 0.1	0.2	-	0.4	-
	N	0.2	-	0.3	0.4
	N - 0.1	0.2	-	-	0.4
	N - 0.2	0.1	0.2	-	0.4
	N - 0.3	0.0	0.2	-	0.4
$8 \leq t < 25\text{mm}$	N + 0.2	0.3	-	0.5	-
	N + 0.1	0.3	-	0.4	0.5
	N	0.3	-	-	0.5
	N - 0.1	0.2	0.3	-	0.5
	N - 0.2	0.1	0.3	-	0.5
	N - 0.3	0.0	0.3	-	0.5
$25 \leq t < 40\text{mm}$	N + 0.3	0.4	-	0.6	-
	N + 0.2	0.4	-	0.5	0.6
	N + 0.1	0.4	-	-	0.6
	N	0.3	0.4	-	0.6
	N - 0.1	0.2	0.4	-	0.6
	N - 0.2	0.1	0.4	-	0.6
	N - 0.3	0.0	0.4	-	0.6
$40 \leq t < 80\text{mm}$	N + 0.5	0.5	-	0.8	-
	N + 0.4	0.5	-	0.7	0.8
	N + 0.3	0.5	-	0.6	0.8
	N + 0.2	0.5	-	-	0.8
	N + 0.1	0.4	0.5	-	0.8
	N	0.3	0.5	-	0.8
	N - 0.1	0.2	0.5	-	0.8
	N - 0.2	0.1	0.5	-	0.8
$80 \leq t < 150\text{mm}$	N + 0.6	0.6	-	0.9	-
	N + 0.5	0.6	-	0.8	0.9
	N + 0.4	0.6	-	0.7	0.9
	N + 0.3	0.6	-	-	0.9
	N + 0.2	0.5	0.6	-	0.9
	N + 0.1	0.4	0.6	-	0.9
	N	0.3	0.6	-	0.9
	N - 0.1	0.2	0.6	-	0.9
	N - 0.2	0.1	0.6	-	0.9
	N - 0.3	0.0	0.6	-	0.9

N - Nominal Plate Thickness

Table 1 Limits for minor imperfections left unrepaired

4.3.6 Further Defects

4.3.6.1 Lamination

Investigation to be carried out at the steelmill into the cause and extent of the laminations. Severe lamination is to be repaired by a local insert plates. The minimum breadth of the plate to be repaired by insert is to be:

- 1600mm for shell and strength deck plating in way of cruciform or T-joints,
- 800mm for shell, strength deck plating and other primary members,
- 300mm for other structural members.

Local limited lamination may be repaired by chipping and/or grinding followed by welding in accordance with sketch (a). In case where the local limited lamination is near the plate surface, the repair may be carried out as shown in sketch (b). For limitations see paragraph 4.3.5.



4.3.6.2 Weld Spatters

Loose weld spatters are to be removed completely by grinding to clean metal (see Table 9.13) on:

- shell plating
- deck plating on exposed decks
- in tanks for chemical cargoes
- in tanks for fresh water and for drinking water
- in tanks for lubricating oil, hydraulic oil, including service tanks

5. Cutting

5.1 Gas Cutting

The deviation **u** of cut edges (see sketch (a)), from a right angle or from a required slope, and the roughness of the cut edges **R**, is to meet the following requirements:

Mechanised Gas Cutting

Cut Thickness	Standard	Limit
a≤20mm	u=0.6mm R=100µm	u=1.2mm R=150µm
a>20mm	u=0.75mm R=100µm	u=1.5mm R=150µm

Manual Gas Cutting: Free Edges

Strength Members	Standard	Limit
	u=1.5mm R=150µm	u=1.5mm R=300µm
Others	u=1.5mm R=300µm	u=1.5mm R=500µm

Manual Gas Cutting: Welding Edges

	Standard	Limit
Strength Members	u=1.5mm R=400µm	u=1.5mm R=800µm*
Others	u=1.5mm R=800µm*	u=1.5mm R=1500µm*

Individual non-sharp notches caused by torch failures (scouring) are not to be greater than 3mm in depth. Deeper scores should be removed by grinding.

* Unless the welding procedure needs smaller tolerances.

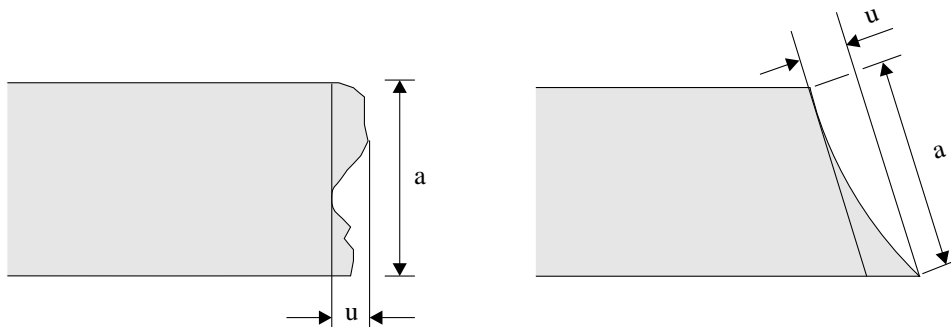

(a) deviation u from a right angle or from a required slope

5.2 Plasma Arc Cutting

The deviation u of the cut edge (see sketch (a)), from a right angle or from a required slope, and the roughness of the cut edge R , is to meet the following requirements:

Mechanised Plasma Arc Cutting

Cut Thickness	Standard	Limit
$a \leq 20\text{mm}$	u=1.0mm R=100µm	u=1.5mm R=150µm
$a > 20\text{mm}$	u=0.75mm R=100µm	u=1.5mm R=150µm

The tolerances for manual cutting are to be agreed by the Classification Society concerned.

5.3 Laser Beam Cutting

The standard range and the tolerance limits for the deviation from a right angle or from a required slope of the cut edges and the roughness of the cut edges are to be agreed by the Classification Society concerned.

6. Fabrication and fairness

- 6.1 Flanged longitudinals and flanged brackets (see Table 6.1)
- 6.2 Built-up sections (see Table 6.2)
- 6.3 Corrugated bulkheads (see Table 6.3)
- 6.4 Pillars, brackets and stiffeners (see Table 6.4)
- 6.5 Maximum heating temperature on surface for line heating (see Table 6.5)
- 6.6 Block assembly (see Table 6.6)
- 6.7 Special sub-assembly (see Table 6.7)
- 6.8 Shape (see Table 6.8 and 6.9)
- 6.9 Fairness of plating between frames (see Table 6.10)
- 6.10 Fairness of plating with frames (see Table 6.11)

7. Alignment

The quality standards for alignment of hull structural components during new construction are shown in Tables 7.1, 7.2 and 7.3. The classification society may require a closer construction tolerance in areas requiring special attention, as follows:

- Regions exposed to high stress concentrations
- Fatigue prone areas
- Detail design block erection joints
- Higher tensile steel regions

8. Welding Details

- 8.1 Typical butt weld plate edge preparation (manual welding) - see Table 8.1 and 8.2
- 8.2 Typical fillet weld plate edge preparation (manual welding) - see Table 8.3 and 8.4
- 8.3 Typical butt and fillet weld profile (manual welding) - see Table 8.5
- 8.4 Lap, plug and slot welding - see Table 8.6
- 8.5 Distance between welds - see Table 8.7
- 8.6 Automatic welding - see Table 8.8

9. Repair

- 9.1 Typical misalignment repair - see Tables 9.1 to 9.3
- 9.2 Typical butt weld plate edge preparation repair (manual welding) - see Table 9.4 and 9.5
- 9.3 Typical fillet weld plate edge preparation repair (manual welding) - see Tables 9.6 to 9.8
- 9.4 Typical fillet and butt weld profile repair (manual welding) - see Table 9.9
- 9.5 Distance between welds repair - see Table 9.10
- 9.6 Erroneous hole repair - see Table 9.11
- 9.7 Repair by insert plate - see Table 9.12
- 9.8 Weld surface repair - see Table 9.13

TABLE 6.1 - FLANGED LONGITUDINALS AND BRACKETS

Detail	Standard	Limit	Remarks
<p>Breadth of flange</p>  <p>compared to correct size</p>	<p>$\pm 3 \text{ mm}$</p>	<p>$\pm 5 \text{ mm}$</p>	
<p>Angle between flange and web</p>  <p>compared to template</p>	<p>$\pm 3 \text{ mm}$</p>	<p>$\pm 5 \text{ mm}$</p>	<p>per 100 mm of a</p>
<p>Straightness in plane of flange and web</p> 	<p>$\pm 10 \text{ mm}$</p>	<p>$\pm 25 \text{ mm}$</p>	<p>per 10 m</p>

TABLE 6.2 - BUILT UP SECTIONS

Detail	Standard	Limit	Remarks
<p>Frames and longitudinal</p> 	<p>$\pm 1.5 \text{ mm}$</p>	<p>$\pm 3 \text{ mm}$</p>	<p>per 100 mm of a</p>
<p>Distortion of face plate</p> 	<p>$d \leq 3 + a/100 \text{ mm}$</p>	<p>$d \leq 5 + a/100 \text{ mm}$</p>	
<p>Distortion of girder and transverse at upper edge and flange</p> 	<p>$\pm 5 \text{ mm}$</p>	<p>$\pm 8 \text{ mm}$</p>	<p>per span between primary members</p>

TABLE 6.3 - CORRUGATED BULKHEADS

Detail	Standard	Limit	Remarks
<p>Mechanical bending</p> 	$R \geq 3t$ mm		<p>Material to be suitable for cold flanging (forming) and welding in way of radius</p>
<p>Depth of corrugation</p> 	± 3 mm	± 6 mm	
<p>Breadth of corugation web</p> 	± 3 mm	± 6 mm	
<p>Breadth of corrugation</p> 	± 3 mm	± 6 mm	
<p>Pitch and depth of swedged corrugated bulkhead compared with correct value</p> 	<p>$h : \pm 2.5$ mm</p> <p>Where it is not aligned with other bulkheads</p> <p>$P : \pm 6$ mm</p> <p>Where it is aligned with other bulkheads</p> <p>$P : \pm 2$ mm</p>	<p>$h : \pm 5$ mm</p> <p>$P : \pm 9$ mm</p> <p>$P : \pm 3$ mm</p>	

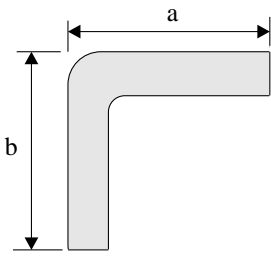
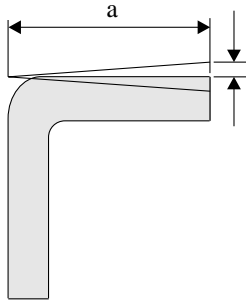
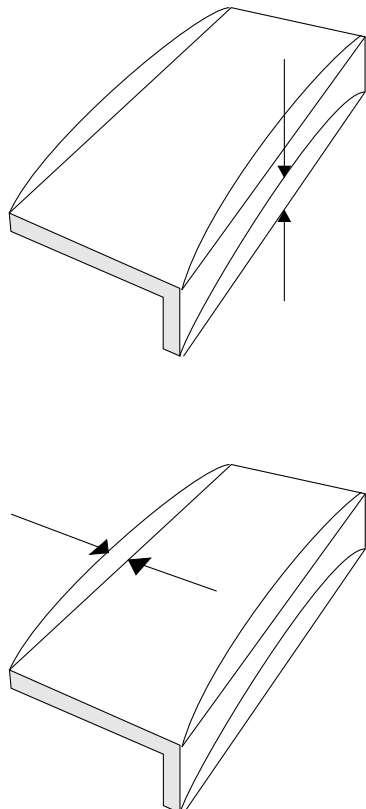
TABLE 6.4 - PILLARS, BRACKETS AND STIFFENERS

Detail	Standard	Limit	Remarks
<p>Pillar (between decks)</p> 	<p>4 mm</p>	<p>6 mm</p>	
<p>Cylindrical structure diameter (pillars, masts, posts, etc.)</p> 	<p>$\pm D/200$ mm max. + 5 mm</p>	<p>$\pm D/150$ mm max. 7.5 mm</p>	
<p>Tripping bracket and small stiffener, distortion at the part of free edge</p> 	<p>$a \leq t/2$ mm</p>	<p>max. 8mm</p>	
<p>Snipe end of secondary face plates and stiffeners</p> 	<p>$\theta^{\circ} = 30^{\circ}$ H = 15 mm D = 25 mm F = 15 mm</p>	<p>+ 5 mm - 5 mm + 10 mm - 5 mm ± 5 mm</p>	

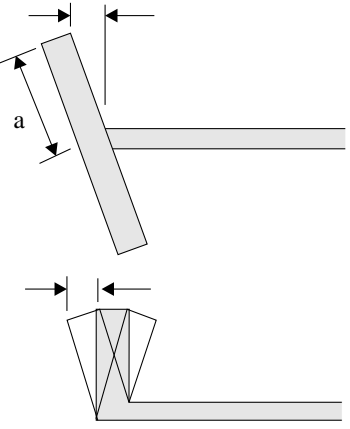
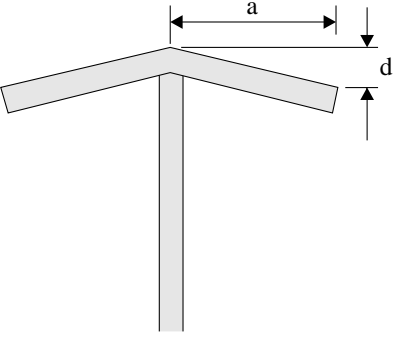
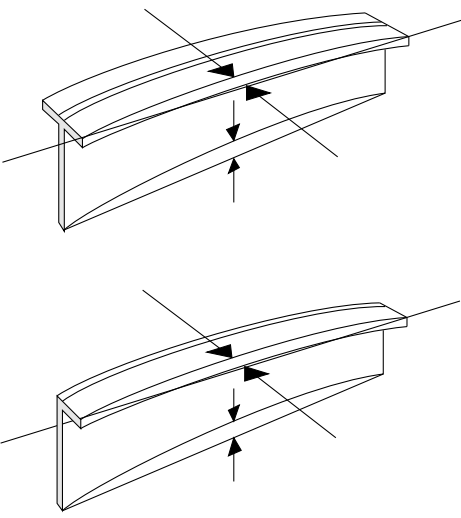
TABLE 6.5 - MAXIMUM HEATING TEMPERATURE ON SURFACE FOR
LINE HEATING FOR PLATE FORMING

Item		Standard	Limit	Remarks
Conventional Process AH32-EH32 & AH36-EH36	Water cooling just after heating	under 650°C		
	Air cooling after heating	under 900°C		
	Air cooling and subsequent water cooling after heating	under 900°C (starting temperature of water cooling to be under 500°C)		
TCMP type AH32-EH32 & AH36-EH36 (Ceq.>0.38%)				
TMCP type AH32-DH32 & AH36-DH36 (Ceq.≤0.38%)	Water cooling just after heating or air cooling	under 1000°C		
TMCP type EH32 & EH36 (Ceq.≤0.38%)	Water cooling just after heating or air cooling	under 900°C		

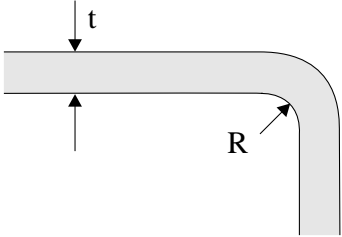
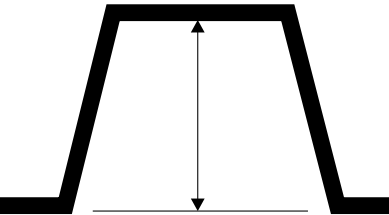
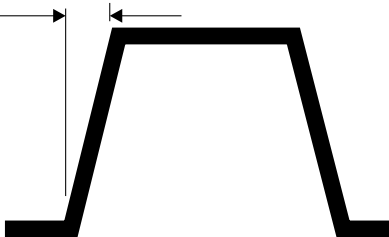
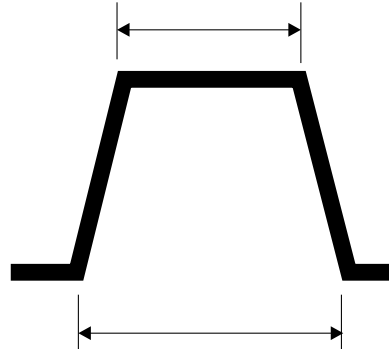
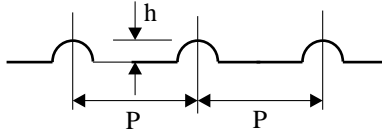
NOTE:

$$Ceq = C + \frac{Mn}{6} + \frac{Cr + Mo + V}{5} + \frac{Ni + Cu}{15} (\%)$$

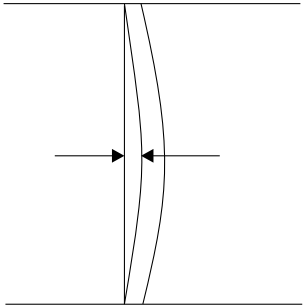
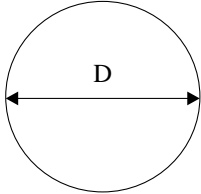
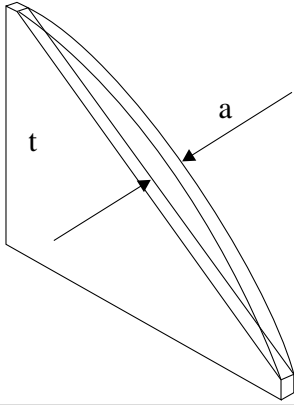
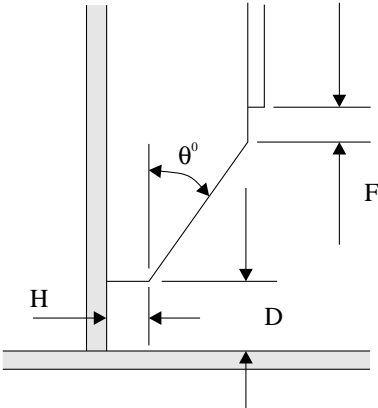
TABLE 6.6 - BLOCK ASSEMBLY

Item	Standard	Limit	Remarks
Flat Plate Assembly			
Length and Breadth	±2.5mm	±5mm	
Distortion	±10mm	±20mm	
Squareness	±5mm	±10mm	
Deviation of interior members from plate	5mm	10mm	
Curved plate assembly			
Length and Breadth	±2.5mm	±5mm	Measured along the girth
Distortion	±10mm	±20mm	
Squareness	±10mm	±15mm	
Deviation of interior members from plate	5mm	10mm	
Flat cubic assembly			
Length and Breadth	±2.5m	±5mm	
Distortion	±10mm	±20mm	
Squareness	±5mm	±10mm	
Deviation of interior members from plate	5mm	10mm	
Twist	±10mm	±20mm	
Deviation between upper and lower plate	±5mm	±10mm	
Curved cubic assembly			
Length and Breadth	±2.5mm	±5mm	measured along with girth
Distortion	±10mm	±20mm	
Squareness	±10mm	±15mm	
Deviation of interior members from plate	5mm	10mm	
Twist	±15mm	±25mm	
Deviation between upper and lower plate	±7mm	±15mm	

TABLE 6.7 - SPECIAL SUB-ASSEMBLY

Item	Standard	Limit	Remarks
Distance between upper/lower gudgeon	±5mm	±10mm	
Distance between aft edge of boss and aft peak bulkhead	±5mm	±10mm	
Twist of sub-assembly of stern frame	5mm	10mm	
Deviation of rudder from shaft centre line	4mm	8mm	
Twist of rudder plate	6mm	10mm	
Flatness of top plate of main engine bed	5mm	10mm	
Breadth and length of top plate of main engine bed	±4mm	6mm	

TABLE 6.8 - SHAPE

Detail	Standard	Limit	Remarks
<p>Deformation for the whole length</p> 	$\pm 50 \text{ mm}$		per 100 m against the line of keel sighting
<p>Deformation for the distance between two adjacent bulkheads</p> 	$\pm 15 \text{ mm}$		
<p>Cocking-up of fore body</p> 	$\pm 30 \text{ mm}$		
<p>Cocking-up of aft-body</p> 	$\pm 20 \text{ mm}$		
<p>Rise of floor amidships</p> 	$\pm 15 \text{ mm}$		

TABLE 6.9 - SHAPE

Item	Standard	Limit	Remarks
Length between perpendiculars	± 50 per 100m		Applied to ships of 100 metre length and above. For the convenience of the measurement the point where the keel is connected to the curve of the stern may be substituted for the fore perpendicular in the measurement of the length.
Length between aft edge of boss and main engine	± 25 mm		
Moulded breadth at midship	± 15 mm		Applied to ships of 15 metre breadth and above. Measured on the upper deck.
Moulded depth at midship	± 10 mm		Applied to ships of 10 metre depth and above.

TABLE 6.10 - FAIRNESS OF PLATING BETWEEN FRAMES

Item		Standard	Limit	Remarks
Shell plate	Parallel part (side & bottom shell)	4mm	8mm	  $300 < s < 1000$
	Fore and aft part	5mm		
Tank top plate	4mm			
Bulkhead	Longl. bulkhead Trans. bulkhead Swash bulkhead	6mm		
Strength deck	Parallel part	4mm	9mm	
	Fore and aft part	6mm		
	Covered part	7mm		
Second deck	Bare part	6mm	8mm	
	Covered part	7mm	9mm	
Forecastle deck poop deck	Bare part	4mm	8mm	
	Covered part	6mm	9mm	
Super structure deck	Bare part	4mm	6mm	
	Covered part	7mm	9mm	
House wall	Outside wall	4mm	6mm	
	Inside wall	6mm	8mm	
	Covered part	7mm	9mm	
Interior member (web of girder, etc)		5mm	7mm	
Floor and girder in double bottom		5mm	7mm	

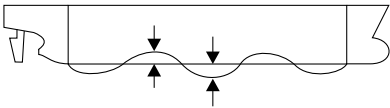
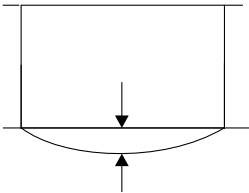
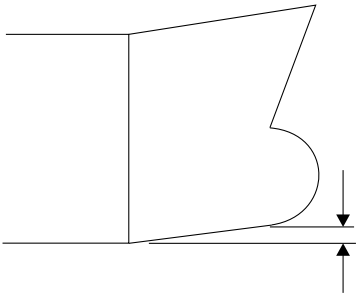
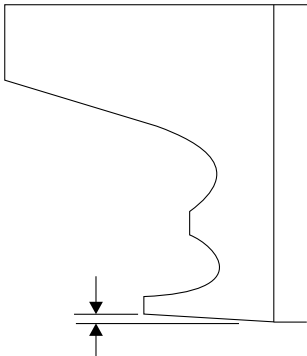
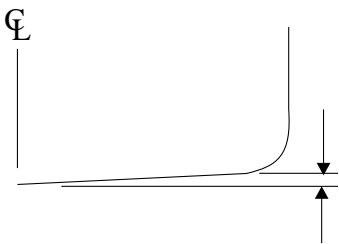
TABLE 6.11 - FAIRNESS OF PLATING WITH FRAMES

Item		Standard	Limit	Remarks
Shell plate	Parallel part	$\pm 2 / 1000\text{mm}$	$\pm 3 / 1000\text{mm}$	To be measured between on trans. space (min. $l=3\text{m}$)
	Fore and aft part	$\pm 3 / 1000\text{mm}$	$\pm 4 / 1000\text{mm}$	
Strength deck (excluding cross deck) and top plate of double bottom	-	$\pm 3 / 1000\text{mm}$	$\pm 4 / 1000\text{mm}$	
Bulkhead	-	$\pm 4 / 1000\text{mm}$	$\pm 5 / 1000\text{mm}$	
Others	-	$\pm 5 / 1000\text{mm}$	$\pm 6 / 1000\text{mm}$	
 <p>$l = \text{span of frame}$ (minimum $l = 3 \text{ m}$)</p>				

TABLE 7.1 - ALIGNMENT

Detail	Standard	Limit	Remarks
<p>Alignment of butt welds</p> 	$a \leq 0.15t$ strength $a \leq 0.2t$ other	$a \leq 3.0$ mm	
<p>Alignment of fillet welds</p>  <p style="text-align: center;">$t_1 < t_2$</p>	<p>a) strength and higher tensile $a \leq t_1/3$ measured on the median</p> <p>$a_1 \leq (5t_1 - 3t_2)/6$ measured on the heel line</p> <p>b) other $a \leq t_1/2$ measured on the median</p> <p>$a_1 \leq (2t_1 - t_2)/2$ measured on the heel line</p>		<p>Where t_3 is less than t_1, then t_3 should be substituted for t_1 in the standard</p>
<p>Alignment of fillet welds</p> 	<p>a) strength and higher tensile steel $a \leq t_1/3$ measured on the median</p> <p>b) other $a_1 \leq t_1/2$ measured on the heel line</p>		

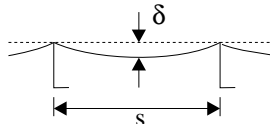
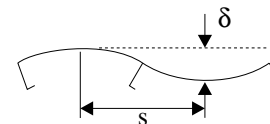
TABLE 7.2 - ALIGNMENT

Detail	Standard	Limit	Remarks
<p>Alignment of flange of T-longitudinal</p> 	$a \leq 0.04b$ strength	$a = 8.0 \text{ mm}$	
<p>Alignment of height of T-bar, L-angle bar or bulb</p> 	<p>Primary members $a \leq 0.15t$</p> <p>Secondary members $a \leq 0.20t$</p>	3.0 mm	
<p>Alignment of panel stiffener</p> 	$d \leq L/50$		
<p>Gap between bracket/intercostal and stiffener</p> 	$a \leq 2.0 \text{ mm}$	3 mm	
<p>Alignment of lap welds</p> 	$a \leq 2.0 \text{ mm}$		

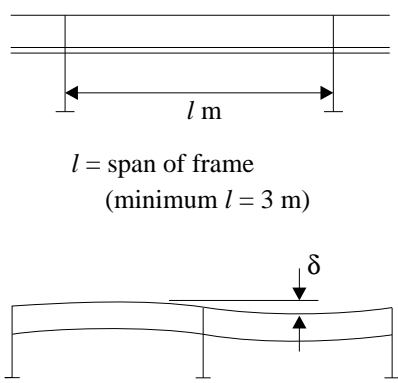
TABLE 7.3 - ALIGNMENT

Detail	Standard	Limit	Remarks
<p>Gap between beam and frame</p> 	<p>$a \leq 2.0 \text{ mm}$</p>		
<p>Position of scallop</p> 	<p>$d \geq 75 \text{ mm}$</p>		
<p>Gap around stiffener cut-out</p> 	<p>$s \leq 2.0 \text{ mm}$</p>		

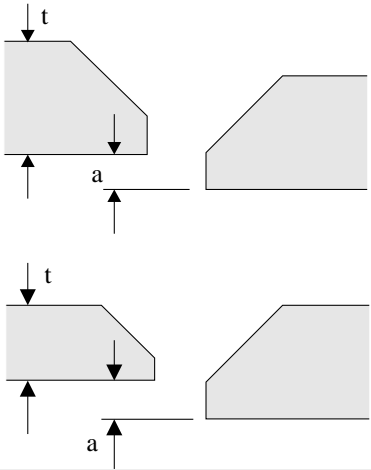
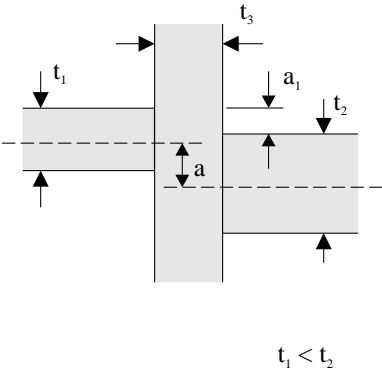
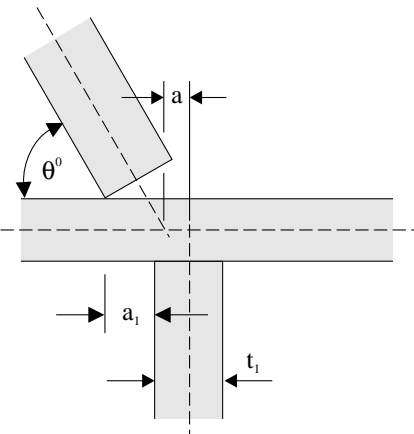
TABLE 8.1 - TYPICAL BUTT WELD PLATE EDGE PREPARATION (MANUAL WELDING)

Detail	Standard	Limit	Remarks
<p>Square butt</p> 	<p>$t \leq 5 \text{ mm}$ $G = 3 \text{ mm}$</p>		<p>see Note 1</p>
<p>Single bevel butt</p> 	<p>$t > 5 \text{ mm}$ $G \leq 3 \text{ mm}$ $R \leq 3 \text{ mm}$ $\theta = 50^\circ - 70^\circ$</p>		<p>see Note 1</p>
<p>Double bevel butt</p> 	<p>$t > 19 \text{ mm}$ $G \leq 3 \text{ mm}$ $R \leq 3 \text{ mm}$ $\theta = 50^\circ - 70^\circ$</p>		<p>see Note 1</p>
<p>Double vee butt, uniform bevels</p> 	<p>$G \leq 3 \text{ mm}$ $R \leq 3 \text{ mm}$ $\theta = 50^\circ - 70^\circ$</p>		<p>see Note 1</p>
<p>Double vee butt, non-uniform bevel</p> 	<p>$G \leq 3 \text{ mm}$ $R \leq 3 \text{ mm}$ $6 \leq h \leq t/3 \text{ mm}$ $\theta = 50^\circ$ $\alpha = 90^\circ$</p>		<p>see Note 1</p>

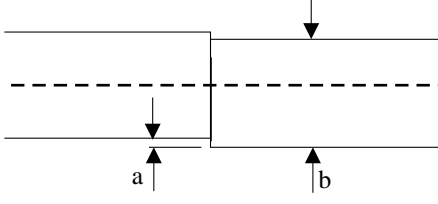
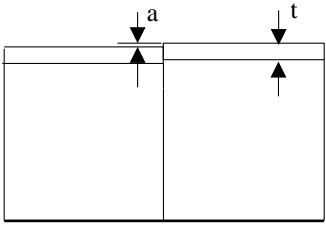
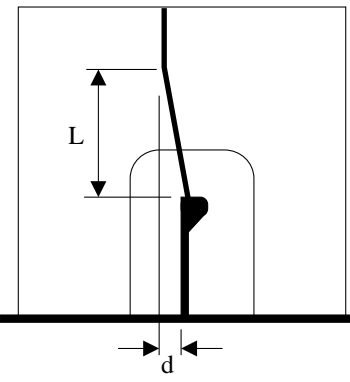
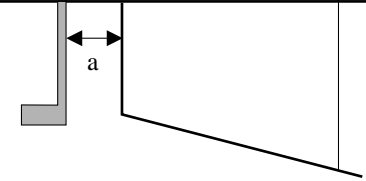
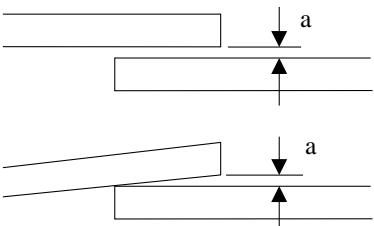
NOTE 1

Different plate edge preparation may be accepted or approved by the Classification Society on the basis of an appropriate welding procedure specification.

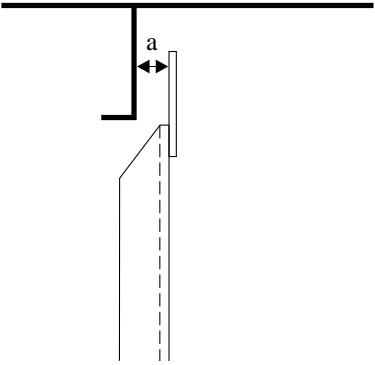
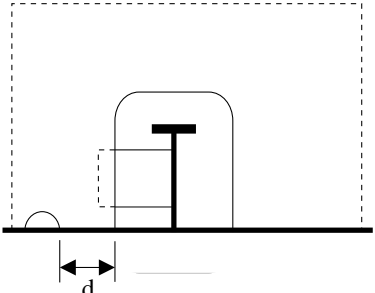
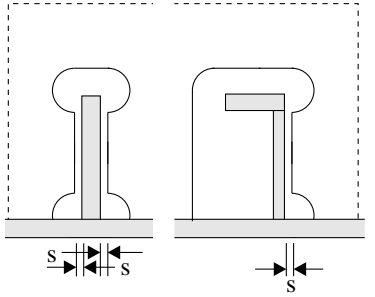
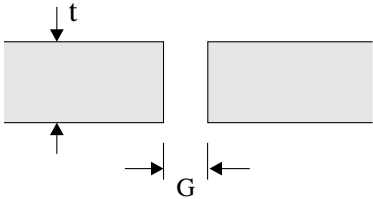
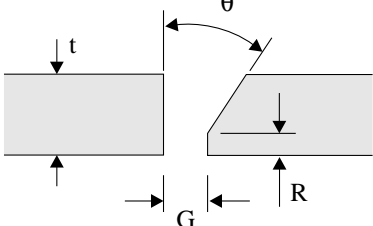
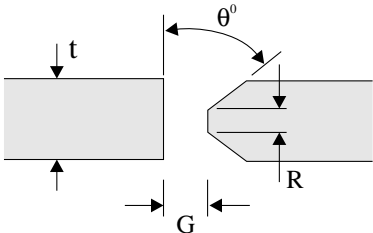
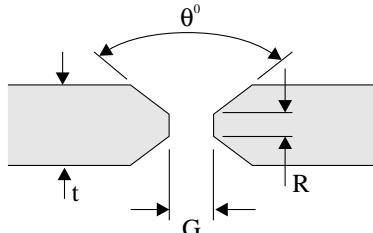
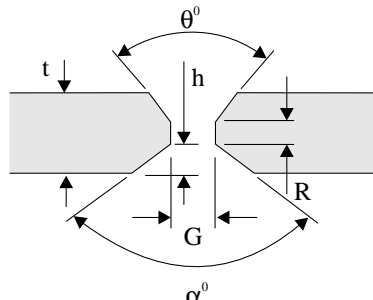
For welding procedures other than manual welding, see paragraph 3.2 Qualification of weld procedures

TABLE 8.2 - TYPICAL BUTT WELD PLATE EDGE PREPARATION (MANUAL WELDING)

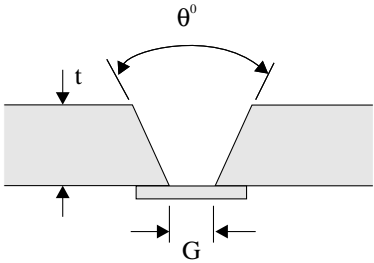
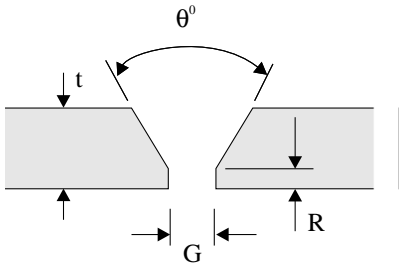
Detail	Standard	Limit	Remarks
<p>Single vee butt, one side welding with backing strip (temporary or permanent)</p> 	<p>$G = 3 - 9 \text{ mm}$ $\theta = 30^\circ - 45^\circ$</p>		<p>see Note 1</p>
<p>Single vee butt</p> 	<p>$G \leq 3 \text{ mm}$ $\theta = 50^\circ - 70^\circ$ $R \leq 3 \text{ mm}$</p>		<p>see Note 1</p>

NOTE 1

Different plate edge preparation may be accepted or approved by the Classification Society on the basis of an appropriate welding procedure specification.

For welding procedures other than manual welding, see paragraph 3.2 Qualification of weld procedures

TABLE 8.3 - TYPICAL FILLET WELD PLATE EDGE PREPARATION (MANUAL WELDING)

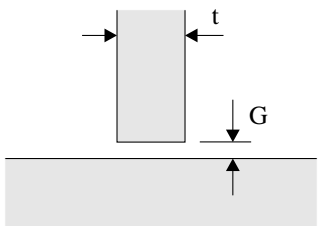
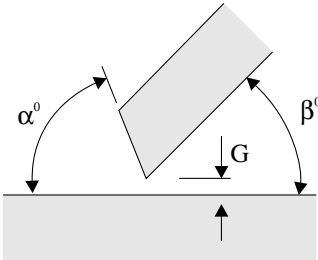
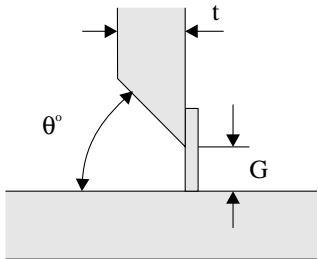
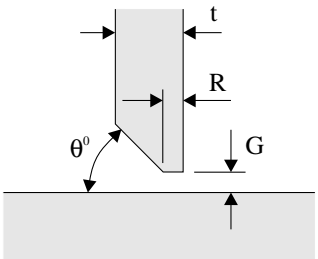
Detail	Standard	Limit	Remarks
<p>Tee Fillet</p> 	<p>$G \leq 2 \text{ mm}$</p>		<p>see Note 1</p>
<p>Small angle fillet</p> 	<p>$\alpha = 50^\circ - 70^\circ$ $\beta = 70^\circ - 90^\circ$ $G \leq 2 \text{ mm}$</p>		<p>see Note 1</p>
<p>Single bevel tee with permanent backing</p> 	<p>$G \leq 4 - 6 \text{ mm}$ $\theta^\circ = 30^\circ - 45^\circ$</p>		<p>Not normally for strength members also see Note 1</p>
<p>Single bevel tee</p> 	<p>$G \leq 3 \text{ mm}$ $R \leq 3 \text{ mm}$ $\theta = 50^\circ$</p>		<p>see Note 1</p>

NOTE 1

Different plate edge preparation may be accepted or approved by the Classification Society on the basis of an appropriate welding procedure specification.

For welding procedures other than manual welding, see paragraph 3.2 Qualification of weld procedures

TABLE 8.4 - TYPICAL FILLET WELD PLATE EDGE PREPARATION (MANUAL WELDING)

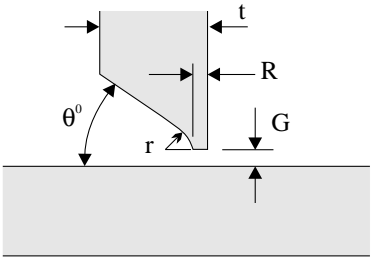
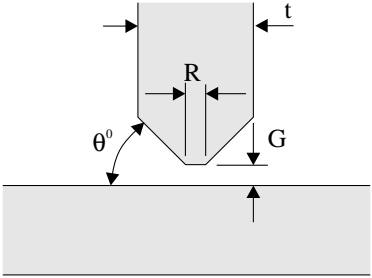
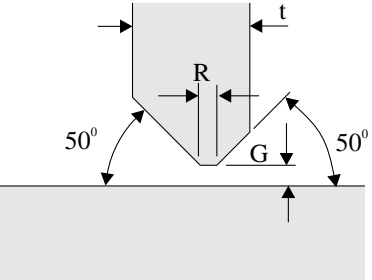
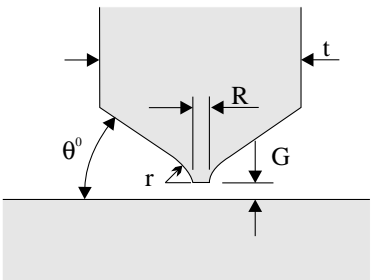
Detail	Standard	Limit	Remarks
<p>Single 'J' tee</p> 	<p>$G = 2.5 - 4 \text{ mm}$ $r = 12 - 15 \text{ mm}$ $R = 3 \text{ mm}$ $\theta \geq 35^\circ$</p>		<p>see Note 1</p>
<p>Double bevel tee symmetrical</p> 	<p>$t > 19 \text{ mm}$ $G \leq 3 \text{ mm}$ $R \leq 3 \text{ mm}$ $\theta = 50^\circ$</p>		<p>see Note 1</p>
<p>Double bevel tee assymetrical</p> 	<p>$t > 19 \text{ mm}$ $G \leq 3 \text{ mm}$ $R \leq 3 \text{ mm}$</p>		<p>see Note 1</p>
<p>Double J bevel symmetrical</p> 	<p>$G = 2.5 - 4 \text{ mm}$ $R \leq 3 \text{ mm}$ $r = 12 - 15 \text{ mm}$ $\theta \geq 35^\circ$</p>		<p>see Note 1</p>

NOTE 1

Different plate edge preparation may be accepted or approved by the Classification Society on the basis of an appropriate welding procedure specification.

For welding procedures other than manual welding, see paragraph 3.2 Qualification of weld procedures

TABLE 8.5 -TYPICAL BUTT AND FILLET WELD PROFILE (MANUAL WELDING)

Detail	Standard	Limit	Remarks
<p>Butt weld toe angle</p> 	<p>$\theta \leq 60^\circ$ $h \leq 0.2R$</p>	<p>maximum $h \leq 6 \text{ mm}$</p>	
<p>Butt weld undercut</p> 	<p>$D = 0 \text{ mm}$</p>	<p>0.5 mm</p>	
<p>Fillet weld leg length</p> 	<p>$s = \text{leg length}$ $a = \text{throat depth}$</p>	<p>$s \geq 0.9s_d$ $a \geq 0.9a_d$ over short weld lengths</p>	<p>$s_d = \text{design } s$ $a_d = \text{design } a$</p>
<p>Fillet weld toe angle</p> 		<p>$\theta \leq 90^\circ$</p>	<p>in areas of stress concentration and fatigue, the Class Society may require a lesser angle</p>
<p>Fillet weld undercut</p> 	<p>$D = 0 \text{ mm}$</p>	<p>0.5 mm</p>	

TABLE 8.6 -TYPICAL LAP, PLUG AND SLOT WELDING (MANUAL WELDING)

Detail	Standard	Limit	Remarks																		
<p>Fillet weld in lap joint</p> 	$b = 2t_2 + 25$		location of lap joint to be approved by the Classification Society																		
<p>Fillet weld in joggled lap joint</p> 	$b \geq 2t_2 + 25 \text{ mm}$																				
<p>Plug welding</p> 		<table border="1"> <thead> <tr> <th></th> <th>$t \leq 12 \text{ mm}$</th> <th>$12 < t \leq 25 \text{ mm}$</th> </tr> </thead> <tbody> <tr> <td>l</td> <td>60 mm</td> <td>80 mm</td> </tr> <tr> <td>R</td> <td>6 mm</td> <td>0.5t mm</td> </tr> <tr> <td>θ</td> <td>40°-50°</td> <td>30°</td> </tr> <tr> <td>G</td> <td>12mm</td> <td>t mm</td> </tr> <tr> <td>L</td> <td colspan="2">$> 2l$</td> </tr> </tbody> </table>		$t \leq 12 \text{ mm}$	$12 < t \leq 25 \text{ mm}$	l	60 mm	80 mm	R	6 mm	0.5t mm	θ	40°-50°	30°	G	12mm	t mm	L	$> 2l$		
	$t \leq 12 \text{ mm}$	$12 < t \leq 25 \text{ mm}$																			
l	60 mm	80 mm																			
R	6 mm	0.5t mm																			
θ	40°-50°	30°																			
G	12mm	t mm																			
L	$> 2l$																				
<p>Slot welding</p> 		<table border="1"> <thead> <tr> <th></th> <th>$t \leq 12 \text{ mm}$</th> <th>$t > 12\text{mm}$</th> </tr> </thead> <tbody> <tr> <td>G</td> <td>20 mm</td> <td>2t</td> </tr> <tr> <td>l</td> <td>80 mm</td> <td>100 mm</td> </tr> <tr> <td>L</td> <td colspan="2">$2l - 3l \text{ max. } 250 \text{ mm}$</td> </tr> </tbody> </table>		$t \leq 12 \text{ mm}$	$t > 12\text{mm}$	G	20 mm	2t	l	80 mm	100 mm	L	$2l - 3l \text{ max. } 250 \text{ mm}$								
	$t \leq 12 \text{ mm}$	$t > 12\text{mm}$																			
G	20 mm	2t																			
l	80 mm	100 mm																			
L	$2l - 3l \text{ max. } 250 \text{ mm}$																				

TABLE 8.7 - DISTANCE BETWEEN WELDS

Detail	Standard	Limit	Remarks
<p>Scallops over weld seams</p> 	<p>for $r \geq 30$ mm $d \geq 5$ mm</p>		
<p>Distance between two butt welds</p> 	<p>$d \geq 0$ mm</p>		
<p>Distance between butt weld and fillet weld</p> 	<p>$d \geq 10$ mm</p>		
<p>Distance between butt welds</p> 	<p>for cut-outs $d \geq 30$ mm</p>		
	<p>for margin plates $d \geq 300$ mm</p>	<p>150 mm</p>	

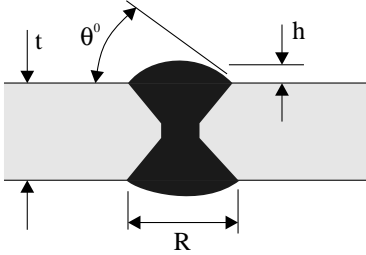
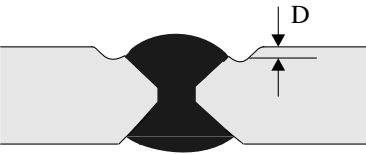
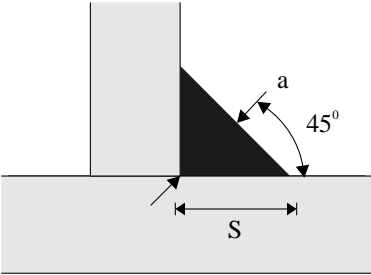
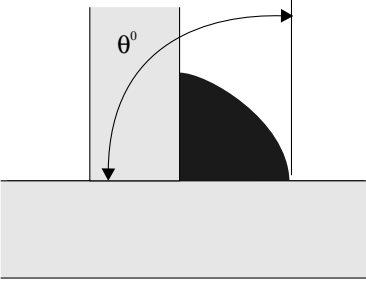
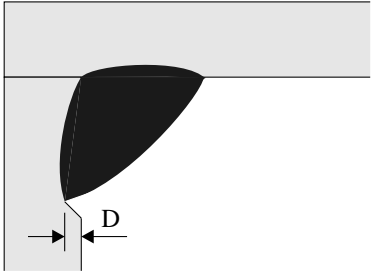
TABLE 8.8 - AUTOMATIC ARC WELDING

Detail	Standard	Limit	Remarks
<p>Submerged Arc Welding (SAW)</p> 	$0 \leq G \leq 0.8 \text{ mm}$	$G \leq 5 \text{ mm}$	<p>Edge preparation as per Tables 8.1 and 8.2</p> <p>SAW may follow WPS approved by the Classification Society</p> <p>see Note 1</p>

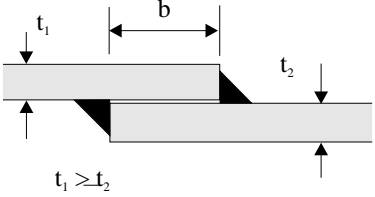
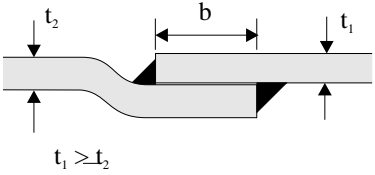
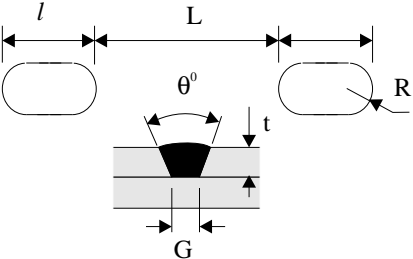
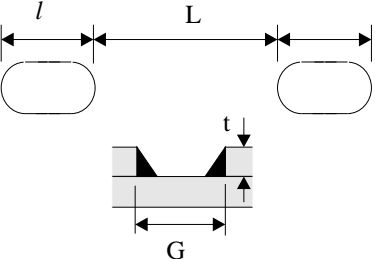
TABLE 9.1 - TYPICAL MISALIGNMENT REPAIR

Detail	Repair standard	Remarks
<p>Alignment of butt joints</p> 	<p>Strength members $a > 0.15t_1$ or $a > 3$ mm release and adjust</p> <p>Others $a > 0.2t_1$ or $a > 3$ mm release and adjust</p>	
<p>Alignment of fillet welds</p>  <p style="text-align: center;">$t_1 < t_2$</p>	<p>a) strength and higher tensile steel</p> <p>$t_1/3 < a \leq t_1/2$ - generally increase weld throat by 10%</p> <p>$a > t_1/2$ - release and adjust over a minimum of 50a</p> <p>b) Other</p> <p>$a > t_1/2$ - release and adjust over a minimum of 30a</p>	<p>Where t_3 is less than t_1, then t_3 should be substituted for t_1 in standard</p>
<p>Alignment of flange of T-longitudinal</p> 	<p>When $0.04b < a \leq 0.08b$, max. 8 mm grind corners to smooth taper over a minimum distance $L=3a$</p> <p>When $a > 0.08b$ or 8 mm release and adjust over minimum $L=50a$</p>	
<p>Alignment of height of T-bar, L-angle bar or bulb</p> 	<p>When $3 \text{ mm} < a \leq 6 \text{ mm}$ building up by welding</p> <p>When $a > 6 \text{ mm}$ release and adjust over minimum $L=50a$ for primary structure and $L=30a$ elsewhere</p> 	
<p>Alignment of lap welds</p> 	<p>$2 \text{ mm} < a \leq 5 \text{ mm}$ weld leg length to be increased by the same amount as increase in gap</p> <p>$a > 5 \text{ mm}$ members to be re-aligned</p>	

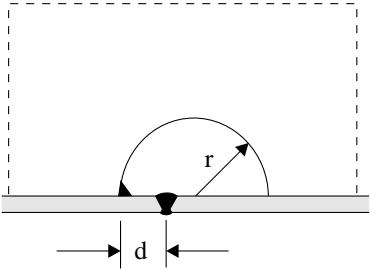
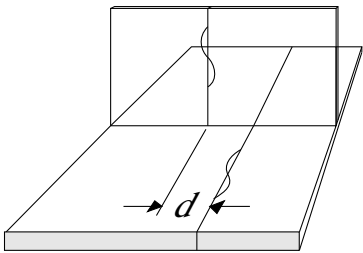
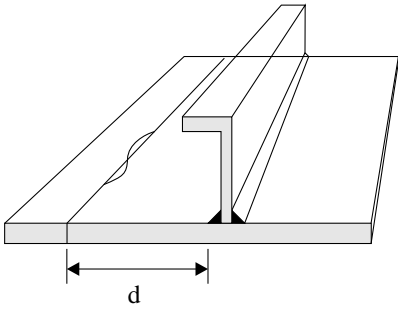
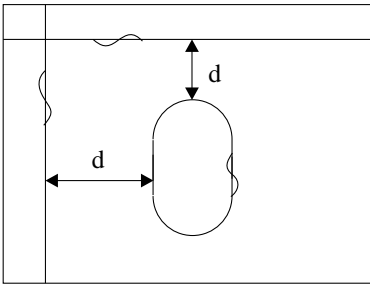
TABLE 9.2 - TYPICAL MISALIGNMENT REPAIR

Detail	Repair standard	Remarks
<p data-bbox="124 302 510 369">Gap between bracket/intercostal and stiffener</p> 	<p data-bbox="638 302 997 403">When $2\text{ mm} < a \leq 5\text{ mm}$ weld leg length to be increased by increase in gap</p> <p data-bbox="638 459 957 560">When $5\text{ mm} < a \leq 10\text{ mm}$ chamfer $30^\circ - 40^\circ$ and build up with welding</p> <p data-bbox="638 616 949 716">When $a > 10\text{ mm}$ increase gap to 50mm and fit collar plate</p>  <p data-bbox="670 1070 997 1104">$b = (2t + 25)\text{ mm}$, min. 50 mm</p>	
<p data-bbox="124 1321 438 1355">Gap between beam and frame</p> 	<p data-bbox="678 1512 997 1545">$a > 2\text{ mm}$ - release and adjust</p>	

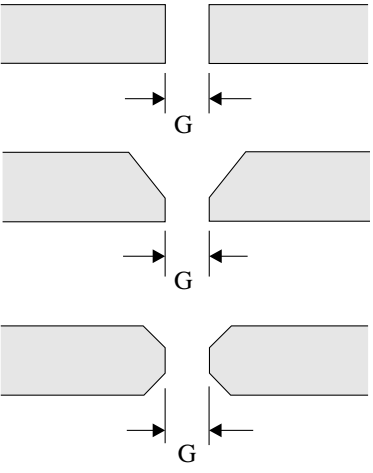
TABLE 9.3 - MISALIGNMENT REPAIR

Detail	Repair standard	Remarks
<p>Position of scallop</p> 	<p>When $d < 75$ mm, web plate to be cut between scallop and slot, and collar plate to be fitted</p>  <p>OR fit small collar over scallop</p>  <p>OR fit collar plate over scallop</p> 	
<p>Gap around stiffener cut-out</p> 	<p>When $2 \text{ mm} < s \leq 5 \text{ mm}$ weld leg length to be increased as much as increase in gap opening over 2 mm</p> <hr/> <p>When $5 \text{ mm} < s \leq 10 \text{ mm}$ nib to be chamfered and built up by welding</p> <hr/> <p>When $s > 10 \text{ mm}$ cut off nib and fit collar plate with same height as nib</p>  <p>$20 \text{ mm} \leq b \leq 50 \text{ mm}$</p>	

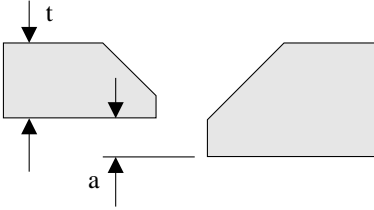
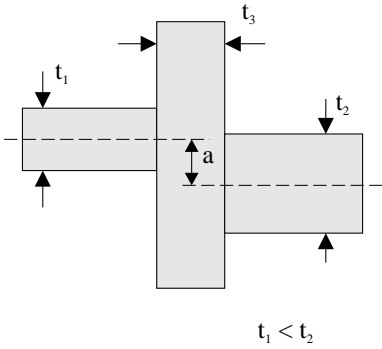
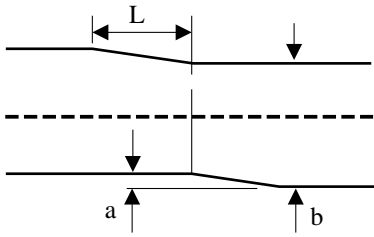
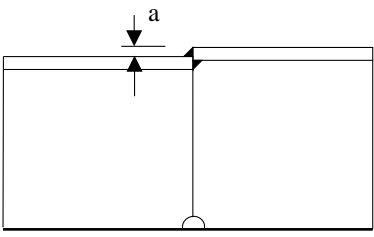
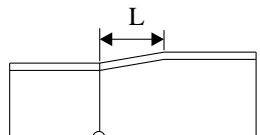
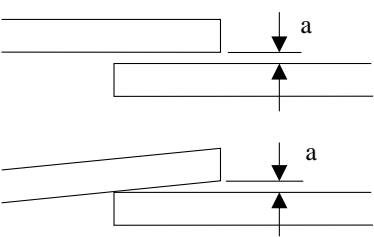
TABLE 9.4 - TYPICAL BUTT WELD PLATE EDGE PREPARATION REPAIR (MANUAL WELDING)

Detail	Repair standard	Remarks
<p>Square butt</p> 	<p>When $G \leq 10$ mm chamfer to 45° and build up by welding</p> <p>When $G > 10$ mm build up with backing strip; remove, back gouge and seal weld; or, insert plate, min. width 300 mm</p>	
<p>Single bevel butt</p> 		
<p>Double bevel butt</p> 	<p>When $3 \text{ mm} < G \leq 3t/2$ mm (maximum 25mm)</p> <p>build up gap with welding on one or both sides of preparation, with possible use of backing strip as necessary, to maximum $t/2$.</p>	
<p>Double vee butt, uniform bevels</p> 	<p>where a backing strip is used, the backing strip is to be removed, the weld back gouged, and a sealing weld made</p>  <p>When $G > 25$ mm or $3t/2$ an insert plate, of minimum width 300mm, to be welded in place</p>	
<p>Double vee butt, non-uniform bevel</p> 		

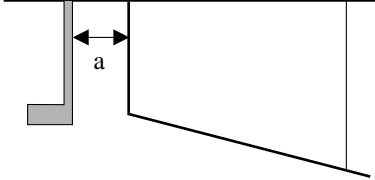
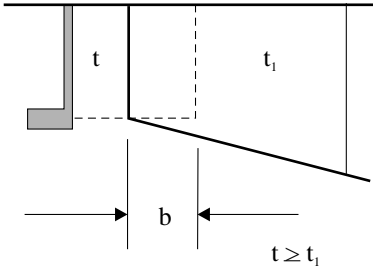
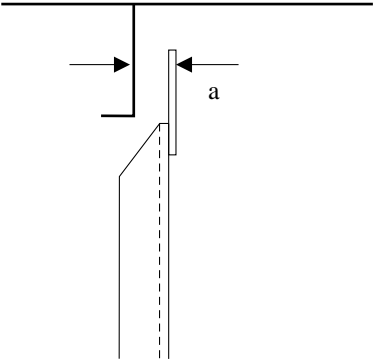
TABLE 9.5 - TYPICAL BUTT WELD PLATE EDGE PREPARATION REPAIR (MANUAL WELDING)

Detail	Repair Standard	Remarks
<p>Single vee butt, one side welding with backing strip</p> 	<p>When $G \leq 25$ mm or $G \leq t/2$ build up edge preparation on one or both sides, grind edge preparation, weld with backing strip, remove backing strip, back gouge, and back weld</p>  <p>When $G > 25$ mm insert plate, min. width 300mm</p> 	
<p>Single vee butt, one side welding</p> 	<p>When $3 \text{ mm} < G \leq 3t/2$ mm (maximum 25mm) build up gap with welding on one or both sides of preparation, with possible use of backing strip as necessary, to maximum $t/2$.</p> <p>Where a backing strip is used, the backing strip is to be removed, the weld back gouged, and a sealing weld made</p> 	
<p>Single vee butt</p> 	<p>When $G > 25$ mm or $t/2$ an insert plate, of minimum width 300mm, to welded in place</p> 	

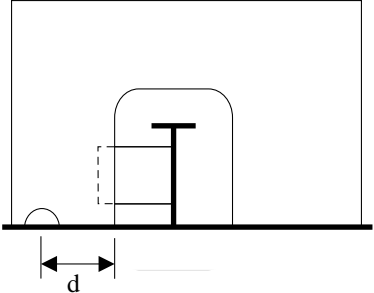
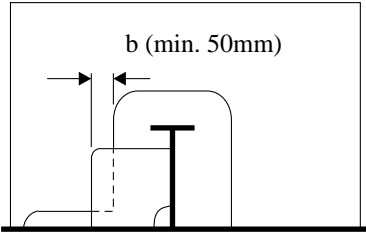
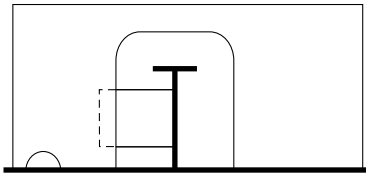
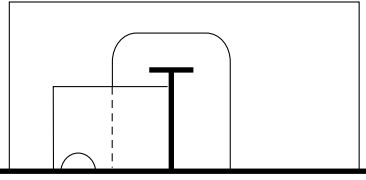
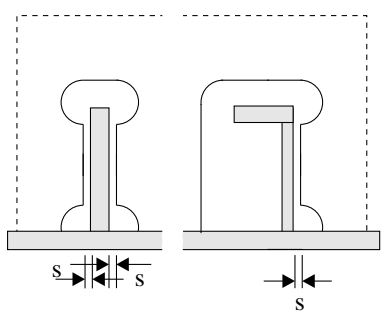
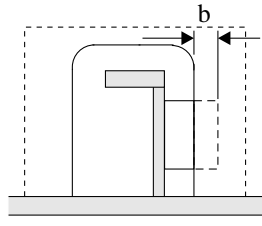
TABLE 9.6 - TYPICAL FILLET WELD PLATE EDGE PREPARATION REPAIR (MANUAL WELDING)

Detail	Repair standard	Remarks
<p data-bbox="135 286 242 315">Tee Fillet</p> 	<p data-bbox="646 286 975 349">$2 \text{ mm} < G \leq 5 \text{ mm}$ - leg length increased to Rule leg + (G - 2)</p> <p data-bbox="646 421 1027 555">$5 \text{ mm} < G \leq 16 \text{ mm}$ - chamfer to 30° to 45°, build up with welding, on one side, with or without backing strip, grind and weld</p>  <p data-bbox="646 1055 1011 1117">$G > 16 \text{ mm}$ or $G > 1.5t$ - new plate to be inserted (min. 300mm)</p> 	
<p data-bbox="135 1641 300 1671">Liner treatment</p> 	<p data-bbox="703 1805 799 1834">$t_2 \leq t \leq t_1$</p> <p data-bbox="703 1839 815 1868">$G \leq 2 \text{ mm}$</p> <p data-bbox="703 1872 999 1901">$a = 5 \text{ mm} + \text{fillet leg length}$</p>	<p data-bbox="1166 1805 1366 1973">Not to be used in cargo area or areas of tensile stress perpendicular to liner</p>

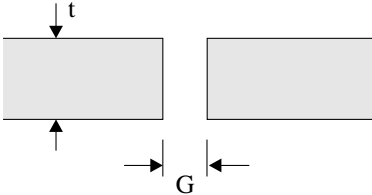
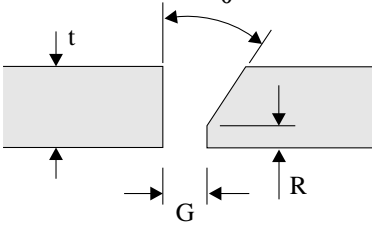
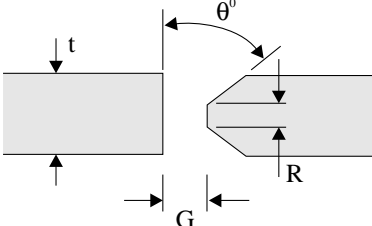
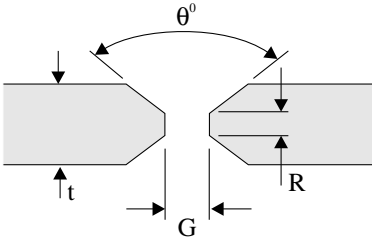
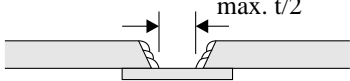
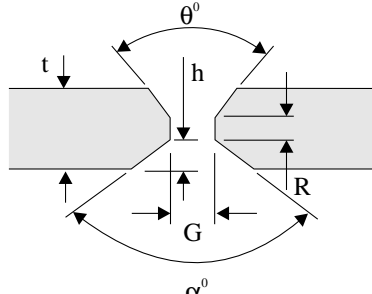
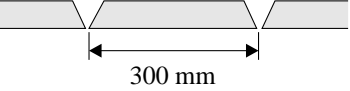
TABLE 9.7 - TYPICAL FILLET WELD PLATE EDGE PREPARATION REPAIR (MANUAL WELDING)

Detail	Repair standard	Remarks
<p>Single bevel tee</p> 	<p>3 mm < G ≤ 5 mm build up weld</p> <hr/> <p>5 mm < G ≤ 16 mm - build up with welding, with or without backing strip, remove backing strip if used, back gouge and back weld</p>  <hr/> <p>G > 16 mm - new plate to be inserted of minimum width 300mm</p> 	

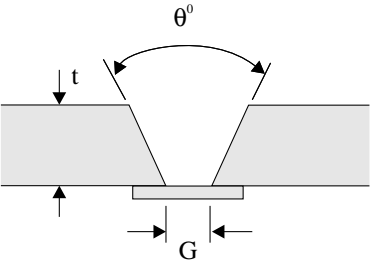
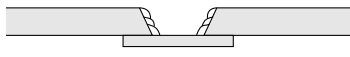
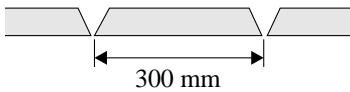
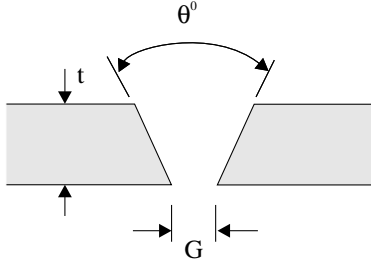
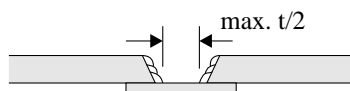
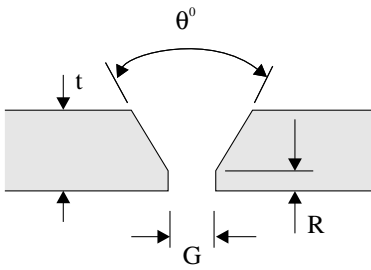
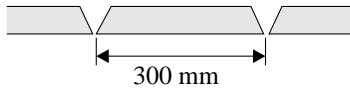
TABLE 9.8 -TYPICAL FILLET WELD PLATE EDGE PREPARATION REPAIR (MANUAL WELDING)

Detail	Repair standard	Remarks
<p>Single 'J' tee</p> 	<p>as single bevel tee</p>	
<p>Double bevel tee symmetrical</p> 	<p>When $3 \text{ mm} < G \leq 16 \text{ mm}$ build up with welding using ceramic or other approved backing bar, remove, back gouge and back weld</p>	
<p>Double bevel tee assymetrical</p> 	 <p>When $G > 16 \text{ mm}$ - insert plate of minimum height 300mm to be fitted</p>	
<p>Double J bevel symmetrical</p> 		

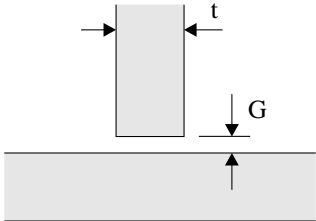
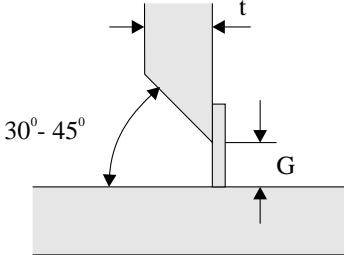
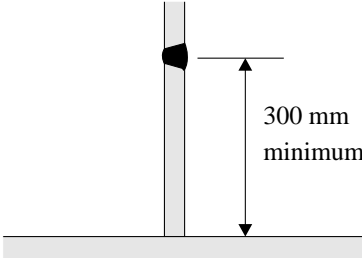
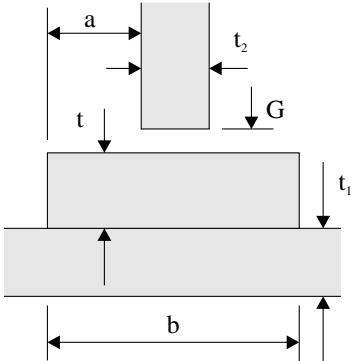
TABLE 9.9 - TYPICAL FILLET AND BUTT WELD PROFILE REPAIR (MANUAL WELDING)

Detail	Repair standard	Remarks
<p>Fillet weld leg length</p> 	<p>Increase leg or throat by welding over</p>	
<p>Fillet weld toe angle</p> 	<p>$\theta > 90^\circ$ grinding, and welding, where necessary, to make $\theta < 90^\circ$</p>	<p>Short beads, less than 50 mm, to be avoided in higher tensile steel</p>
<p>Butt weld toe angle</p> 	<p>$\theta > 90^\circ$ grinding, and welding, where necessary, to make $\theta < 90^\circ$</p>	<p>Microgrooves of ground edge to be parallel to main stress direction</p>
<p>Butt weld undercut</p> 	<p>Where $0.5 < D \leq 1$ mm undercut to be ground smooth (localised only)</p>	
<p>Fillet weld undercut</p> 	<p>Where $D > 1$ mm undercut to be filled by welding</p>	

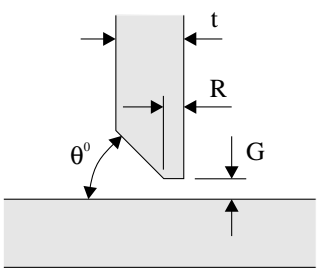
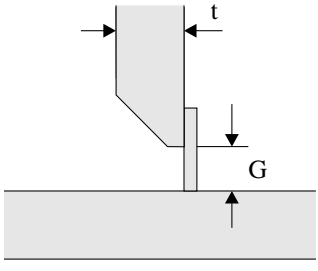
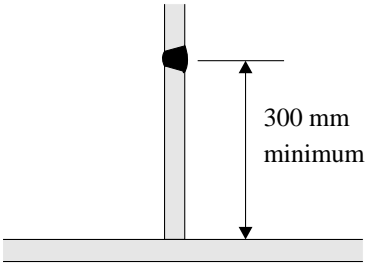
TABLE 9.10 - DISTANCE BETWEEN WELDS REPAIR

Detail	Repair standard	Remarks
<p>Scallops over weld seams</p> 	<p>Hole to be cut and ground smooth to obtain distance</p>	

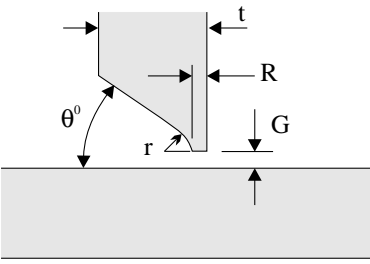
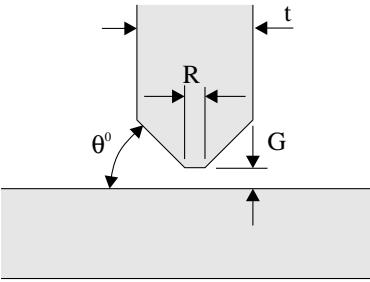
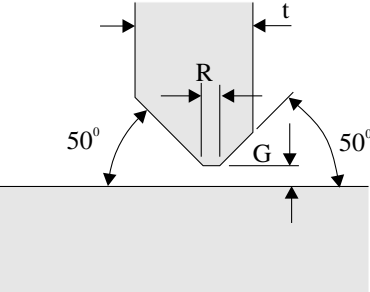
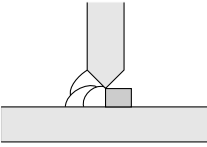
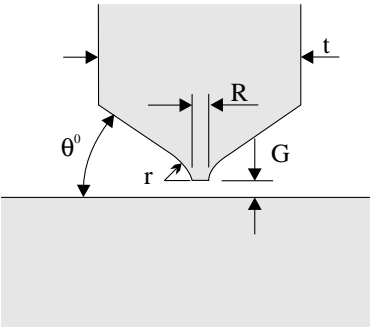
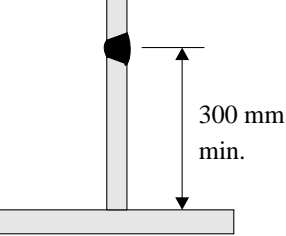
TABLE 9.11 - ERRONEOUS HOLE REPAIR

Detail	Repair standard	Remarks
<p>Holes made erroneously $D < 200$ mm</p> 	<p>Strength members open hole to minimum 75 mm dia., fit and weld spigot piece</p>  <p>$\theta = 30^\circ - 40^\circ$ $G = 4 - 6$ mm $1/2 t \leq t_1 \leq t$ $l = 50$ mm</p> <p>OR open hole to over 300 mm and fit insert plate</p> <hr/> <p>Other members open hole to over 300 mm and fit insert plate OR fit lap plate</p>  <p>$t_1 = t_2$ $L = 50$ mm, min</p>	<p>Fillet weld to be made after butt weld</p> <p>The fitting of spigot pieces in areas of high stress concentration or fatigue is to be approved by the Classification Society</p>
<p>Holes made erroneously $D > 200$ mm</p> 	<p>Strength members open hole to over 300 mm and fit insert plate</p> <hr/> <p>Other members open hole to over 300 mm and fit insert plate OR fit lap plate</p>  <p>$t_1 = t_2$ $L = 50$ mm, min</p>	

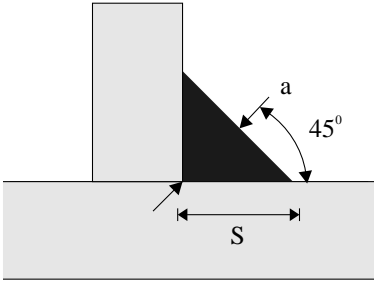
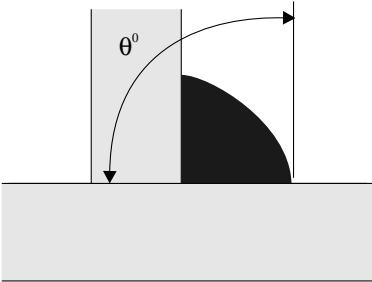
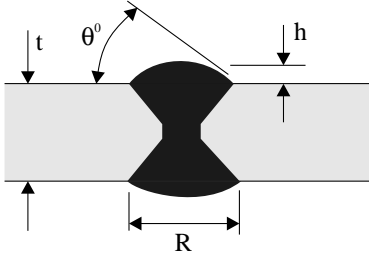
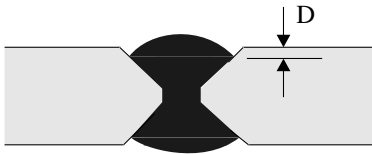
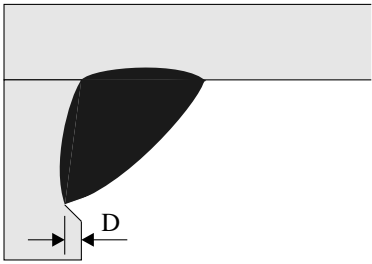
TABLE 9.12 - REPAIR BY INSERT PLATE

Detail	Repair standard	Remarks
<p>Repair by insert plate</p> 	<p> $L = 300 \text{ mm minimum}$ $B = 300 \text{ mm minimum}$ $R = 5t$ 100 mm minimum </p> <p>(1) seam with insert piece is to be welded first</p> <p>(2) original seam is to be released and welded over for a minimum of 100 mm</p>	
<p>Repair of built section by insert plate</p> 	<p> $L_{min} \geq 300 \text{ mm}$ </p> <p>Welding sequence</p> <p>(1) → (2) → (3) → (4)</p> <p>Web butt weld scallop to be filled during final pass (4)</p>	

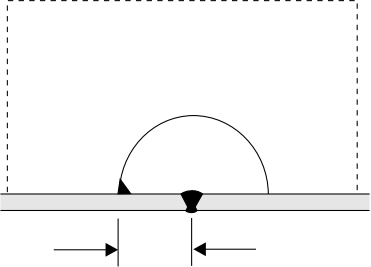
TABLE 9.13 - WELD SURFACE REPAIR

Detail	Repair standard	Remarks
<p data-bbox="165 271 300 297">Weld spatter</p> 	<ol style="list-style-type: none"> <li data-bbox="655 282 1023 383">1. Remove spatter observed before blasting with scraper or chipping hammer, etc. <li data-bbox="655 398 1046 425">2. For spatter observed after blasting: <ol style="list-style-type: none"> <li data-bbox="692 443 1070 506">a) Remove with a chipping hammer, scraper, etc. <li data-bbox="692 517 1066 645">b) For spatter not easily removed with a chipping hammer, scraper, etc., grind the sharp angle of spatter to make it obtuse 	<p data-bbox="1190 293 1390 394">In principal, no grinding is applied to weld surface</p>
<p data-bbox="161 714 448 741">Irregularity of manual weld</p> 	<p data-bbox="663 831 1062 931">When the surface irregularity exceeds 3mm, apply grinding until the irregularity becomes less than 3mm</p>	<p data-bbox="1190 831 1406 931">This repair standard is applicable to fillet welds also</p>
<p data-bbox="165 1167 268 1193">Arc strike</p>	<p data-bbox="663 1211 1078 1238">Remove the hardened zone by grinding</p>	

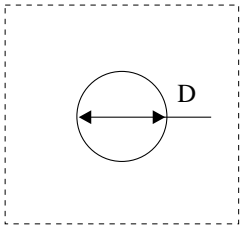
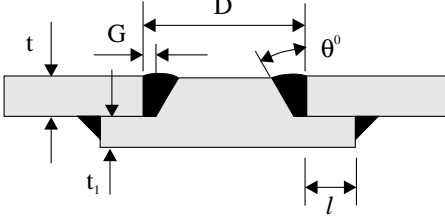
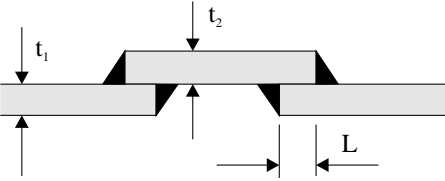
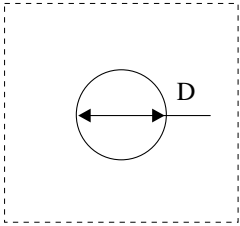
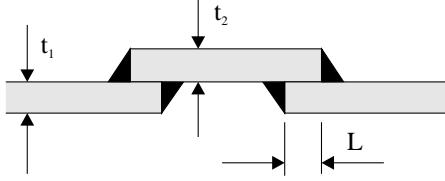
Part B Repair Quality Standard for Existing Ships

PART B -SHIPBUILDING AND REPAIR QUALITY STANDARD FOR EXISTING SHIPS

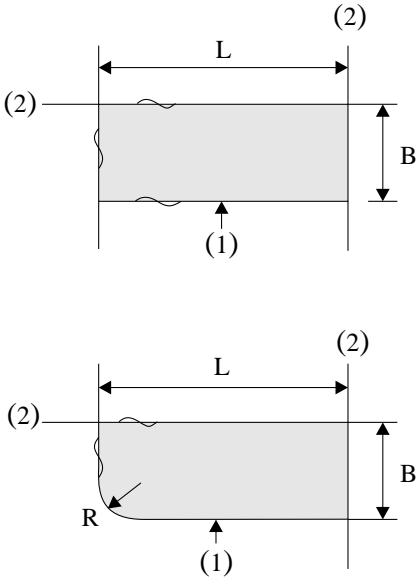
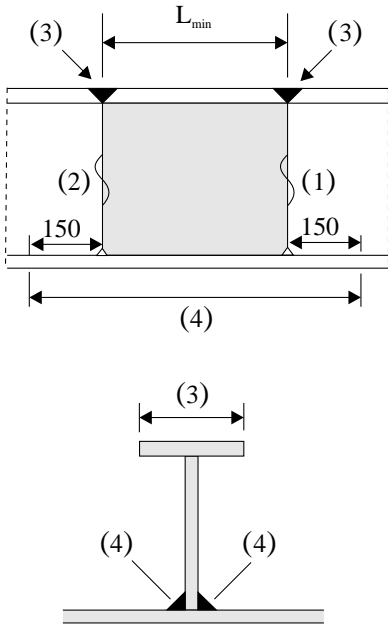
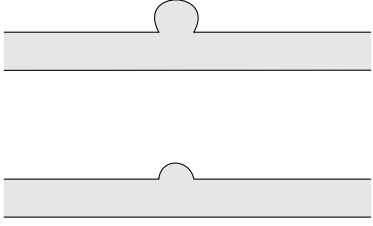
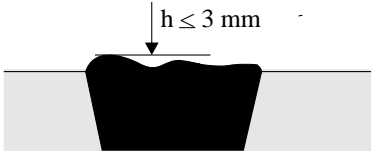
CONTENTS:

1. Scope

2. General requirements to repairs and repairers

3. Qualification of personnel

3.1 Qualification of welders

3.2 Qualification of welding procedures

3.3 Qualification of NDE operators

4. Materials

4.1 General requirements to materials

4.2 Equivalency of material grades

5. General requirements to welding

5.1 Correlation of welding consumables to hull structural steels

5.2 General requirements to preheating and drying out

5.3 Dry welding on hull plating below the waterline of vessels afloat

6. Repair quality standard

6.1 Welding, general

6.2 Renewal of plates

6.3 Doubler on plates

6.4 Renewal of internals/stiffeners

6.5 Renewal of internals/stiffeners - transitions inverted angles/bulb profiles

6.6 Termination of straps

6.7 Welding of pitting corrosion

6.8 Welding repairs of cracks

6.9 Grinding of shallow cracks

REFERENCES

1. IACS "Bulk Carriers - Guidelines for Surveys, Assessment and Repair of Hull Structure"
2. TSCF "Guidelines for the inspection and maintenance of double hull tanker structures"
3. TSCF "Guidance manual for the inspection and condition assessment of tanker structures"
4. IACS UR W 11 "Normal and higher strength hull structural steels"
5. IACS UR W 13 "Allowable under thickness tolerances of steel plates and wide flats"
6. IACS UR W 17 "Approval of consumables for welding normal and higher strength hull structural steels"
7. IACS Z 10.1 "Hull surveys of oil tankers" and Z 10.2 "Hull surveys of bulk carriers" Table IV
8. IACS UR Z 13 "Voyage repairs and maintenance"
9. IACS Recommendation 12 "Guidelines for surface finish of hot rolled steel plates and wide flats"
10. IACS Recommendation 20 "Guide for inspection of ship hull welds"

1. Scope

1.1 This standard provides guidance on quality of repair of hull structures. The standard covers permanent repairs of existing ships.

Whereas the standard generally applies to

- conventional ship types,
 - parts of hull covered by the rules of the Classification Society,
 - hull structures constructed from normal and higher strength hull structural steel,
- the applicability of the standard is in each case to be agreed upon by the Classification Society.

The standard does generally not apply to repair of

- special types of ships as e.g. gas tankers
- structures fabricated from stainless steel or other, special types or grades of steel

1.2 The standard covers typical repair methods and gives guidance on quality standard on the most important aspects of such repairs. Unless explicitly stated elsewhere in the standard, the level of workmanship reflected herein will in principle be acceptable for primary and secondary structure of conventional design. A more stringent standard may however be required for critical and highly stressed areas of the hull, and is to be agreed with the Classification Society in each case. In assessing the criticality of hull structure and structural components, reference is made to ref. 1, 2 and 3.

1.3 Restoration of structure to the original standard may not constitute durable repairs of damages originating from insufficient strength or inadequate detail design. In such cases strengthening or improvements beyond the original design may be required. Such improvements are not covered by this standard, however it is referred to ref. 1, 2 and 3.

2. General requirements for repairs and repairers

2.1 In general, when hull structure covered by classification is to be subjected to repairs, the work is to be carried out under the supervision of the Surveyor to the Classification Society. Such repairs are to be agreed prior to commencement of the work.

2.2 Repairs are to be carried out by workshops, repair yards or personnel who have demonstrated their capability to carry out hull repairs of adequate quality in accordance with the Classification Society's requirements and this standard.

2.3 Repairs are to be carried out under working conditions that facilitate sound repairs. Provisions are to be made for proper accessibility, staging, lighting and ventilation. Welding operations are to be carried out under shelter from rain, snow and wind.

2.4 Welding of hull structures is to be carried out by qualified welders, according to approved and qualified welding procedures and with welding consumables approved by the Classification Society, see Section 3. Welding operations are to be carried out under proper supervision of the repair yard.

2.5 Where repairs to hull which affect or may affect classification are intended to be carried out during a voyage, complete repair procedure including the extent and sequence of repair is to be submitted to and agreed upon by the Surveyor to the Classification Society reasonably in advance of the repairs. See Ref. 8.

3. Qualification of personnel

3.1 Qualification of welders

3.1.1 Welders are to be qualified in accordance with the procedures of the Classification Society or to a recognised national or international standard, e.g. EN 287, ISO 9606, ASME Section IX, ANSI/AWS D1.1. Recognition of other standards is subject to submission to the Classification Society for evaluation. Repair yards and workshops are to keep records of welders qualification and, when required, furnish valid approval test certificates.

3.1.2 Welding operators using fully mechanised or fully automatic processes need generally not pass approval testing, provided that production welds made by the operators are of the required quality. However, operators are to receive adequate training in setting or programming and operating the equipment. Records of training and production test results shall be maintained on individual operator's files and records, and be made available to the Classification Society for inspection when requested.

3.2 Qualification of welding procedures

Welding procedures are to be qualified in accordance with the procedures of the Classification Society or a recognised national or international standard, e.g. EN288, ISO 9956, ASME Section IX, ANSI/AWS D1.1. Recognition of other standards is subject to submission to the Classification Society for evaluation. The welding procedure should be supported by a welding procedure qualification record. The specification is to include the welding process, types of electrodes, weld shape, edge preparation, welding techniques and positions

3.3 Qualification of NDE operators

3.3.1 Personnel performing non destructive examination for the purpose of assessing quality of welds in connection with repairs covered by this standard, are to be qualified in accordance with the Classification Society rules or to a recognised international or national qualification scheme. Records of operators and their current certificates are to be kept and made available to the Surveyor for inspection.

4. Materials

4.1. General requirements for materials

4.1.1 The requirements for materials used in repairs are in general the same as the requirements for materials specified in the Classification Society's rules for new constructions, (ref. 5)

4.1.2 Replacement material is in general to be of the same grade as the original approved material. Alternatively, material grades complying with recognised national or international standards may be accepted by the Classification Societies provided such standards give equivalence to the requirements of the original grade or are agreed by the Classification Society. For assessment of equivalency between steel grades, the general requirements and guidelines in Section 4.2 apply.

4.1.3 Higher tensile steel is not to be replaced by steel of a lesser strength unless specially approved by the Classification Society.

4.1.4 Normal and higher strength hull structural steels are to be manufactured at works approved by the Classification Society for the type and grade being supplied.

4.1.5 Materials used in repairs are to be certified by the Classification Society applying the procedures and requirements in the rules for new constructions. In special cases, and normally limited to small quantities, materials may be accepted on the basis of alternative procedures for verification of the material's properties. Such procedures are subject to agreement by the Classification Society in each separate case.

4.2. Equivalency of material grades

4.2.1 Assessment of equivalency between material grades should at least include the following aspects;

- heat treatment/delivery condition
- chemical composition
- mechanical properties
- tolerances

4.2.2 When assessing the equivalence between grades of normal or higher strength hull structural steels up to and including grade E40 in thickness limited to 50 mm, the general requirements in Table 4.1 apply.

4.2.3 Guidance on selection of steel grades to certain recognised standards equivalent to hull structural steel grades specified in Classification Societies' rules is given in Table 4.2

5. General requirements to welding

5.1 Correlation of welding consumables with hull structural steels

5.1.1 For the different hull structural steel grades welding consumables are to be selected in accordance with IACS UR W17 (see Ref.5).

5.2 General requirements to preheating and drying out

5.2.1 The need for preheating is to be determined based on the chemical composition of the materials, welding process and procedure and degree of joint restraint.

5.2.2 A minimum preheat of 50° C is to be applied when ambient temperature is below 0°C. Dryness of the welding zone is in all cases to be ensured.

5.2.3 Guidance on recommended minimum preheating temperature for higher strength steel is given in Table 5.1. For automatic welding processes utilising higher heat input e.g. submerged arc welding, the temperatures may be reduced by 50° C. For re-welding or repair of welds, the stipulated values are to be increased by 25 ° C.

Items to be considered	Requirements	Comments
Chemical composition	<ul style="list-style-type: none"> - C; equal or lower - P and S; equal or lower - Mn; approximately the same but not exceeding 1.6% - Fine grain elements; in same amount - Deoxidation practice 	The sum of the elements, e.g. Cu, Ni, Cr and Mo should not exceed 0.8%
Mechanical properties	<ul style="list-style-type: none"> - Tensile strength; equal or higher - Yield strength; equal or higher - Elongation; equal or higher - Impact energy; equal or higher at same or lower temperature, where applicable 	Actual yield strength should not exceed Classification Society Rule minimum requirements by more than 80 N/mm ²
Condition of supply	Same or better	Heat treatment in increasing order; <ul style="list-style-type: none"> - as rolled (AR) - controlled rolled (CR) - normalised (N) - thermo-mechanically rolled (TM)¹⁾ - quenched and tempered (QT)¹⁾ 1) TM- and QT-steels are not suitable for hot forming
Tolerances	- Same or stricter	Permissible under thickness tolerances; <ul style="list-style-type: none"> - plates: 0.3 mm - sections: according to recognised standards

Table 4.1 Minimum extent and requirements to assessment of equivalency between normal or higher strength hull structural steel grades

5.3 Dry welding on hull plating below the waterline of vessels afloat

5.3.1. Welding on hull plating below the waterline of vessels afloat is acceptable only on normal and higher strength steels with specified yield strength not exceeding 355 MPa and only for local repairs. Welding involving other high strength steels or more extensive repairs against water backing is subject to special consideration and approval by the Classification Society of the welding procedure.

5.3.2. Low-hydrogen electrodes or welding processes are to be used when welding on hull plating against water backing. Coated low-hydrogen electrodes used for manual metal arc welding should be properly conditioned to ensure a minimum of moisture content.

5.3.3 In order to ensure dryness and to reduce the cooling rate, the structure is to be preheated by a torch or similar prior to welding, to a temperature of minimum 5°C or as specified in the welding procedure.

Table 4.2 Guidance on steel grades comparable to the normal and high strength hull structural steel grades given in Classification Society rules

Steel grades according to Classification Societies' rules (ref. 5)						Comparable steel grades				
Grade	Yield stress R _{eH} min. N/mm ²	Tensile strength R _m N/mm ²	Elongation A ₅ min. %	Average impact energy		ISO 630-80 4950/2/3 1981	EN EN 10025-93 EN 10113-93	ASTM A 131	JIS G 3106	
				Temp. °C	J, min. L T					
A	235	400 - 502	22	+20	-	Fe 360B	S235JRG2	A	SM41B	
B				0	27	20	Fe 360C	S235J0	B	SM41B
D				-20	27	20	Fe 360D	S235J2G3	D	(SM41C)
E				-40	27	20	-	S275NL/ML	E	-
A 27				265	400 - 530	22	0		Fe 430C	S275J0G3
D 27	-20	27	20				Fe 430D	S275N/M	-	-
E 27	-40						-	S275NL/ML	-	-
A 32	315	440 - 590	22	0		-	-	AH32	SM50B	
D 32				-20			-	-	DH32	(SM50C)
E 32				-40	31	22	-	-	EH32	-
A 36	355	490 - 620	21	0		Fe 510C	S355N/M	AH36	SM53B	
D 36				-20			Fe 510D	S355N/M	DH36	(SM53C)
E 36				-40	34	24	E355E	S355NL/ML	EH36	-
A 40	390	510 - 650	20	0		E390CC	S420N/M	AH40	(SM58)	
D 40				-20			E390DD	S420N/M	DH40	-
E 40				-40	41	27	E390E	S420NL/ML	EH40	-

Note : In selecting comparable steels from this table, attention should be given to the requirements of Table 4.1 and the dimension requirements of the product with respect to Classification Society rules.

Carbon equivalent 1)	Recommended minimum preheat temperature (° C)		
	$t_{\text{comb}} \leq 50 \text{ mm}$ 2)	$50 \text{ mm} < t_{\text{comb}} \leq 70 \text{ mm}$ 2)	$t_{\text{comb}} > 70 \text{ mm}$ 2)
$C_{\text{eq}} \leq 0.39$	-	6	
$C_{\text{eq}} \leq 0.41$	-	3	
$C_{\text{eq}} \leq 0.43$	-	50	100
$C_{\text{eq}} \leq 0.45$	50	100	125
$C_{\text{eq}} \leq 0.47$	100	125	150
$C_{\text{eq}} \leq 0.50$	125	150	175

Table 5.1 Preheating temperature

NOTES

$$1) C_{\text{eq}} = C + \frac{\text{Mn}}{6} + \frac{\text{Cr} + \text{Mo} + \text{V}}{5} + \frac{\text{Ni} + \text{Cu}}{15} (\%)$$

2) Combined thickness $t_{\text{comb}} = t_1 + t_2 + t_3 + t_4$, see figure

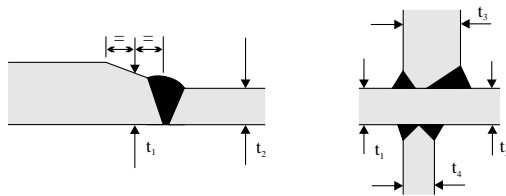

6. Repair quality standard

6.1 Welding, general

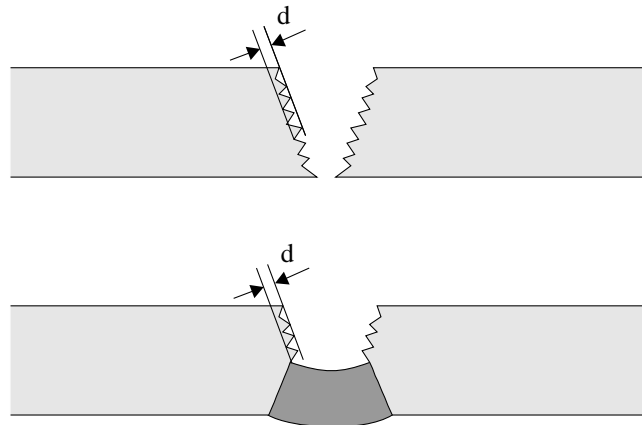

Fig. 6.1 Groove roughness

Item	Standard	Limit	Remarks
Material Grade	Same as original or higher		See Section 4
Welding Consumables	IACS UR-W17 (ref. 6)	Approval according to equivalent international standard	
Groove / roughness	See note and Fig. 6.1	$d < 1.5 \text{ mm}$	Grind smooth
Pre-Heating	See Table 5.1	Steel temperature not lower than 5°C	
Welding with water on the outside	See Section 5.3	Acceptable for normal and high strength steels	-Moisture to be removed by a heating torch
Alignment	As for new construction		
Weld finish	IACS guide for inspection of ship hull welds (ref. 10)		
NDE	IACS guide (ref. 10)	At random with extent to be agreed with attending surveyors	

NOTE :

Slag, grease, loose mill scale, rust and paint, other than primer, to be removed.

6.2 Renewal of plates

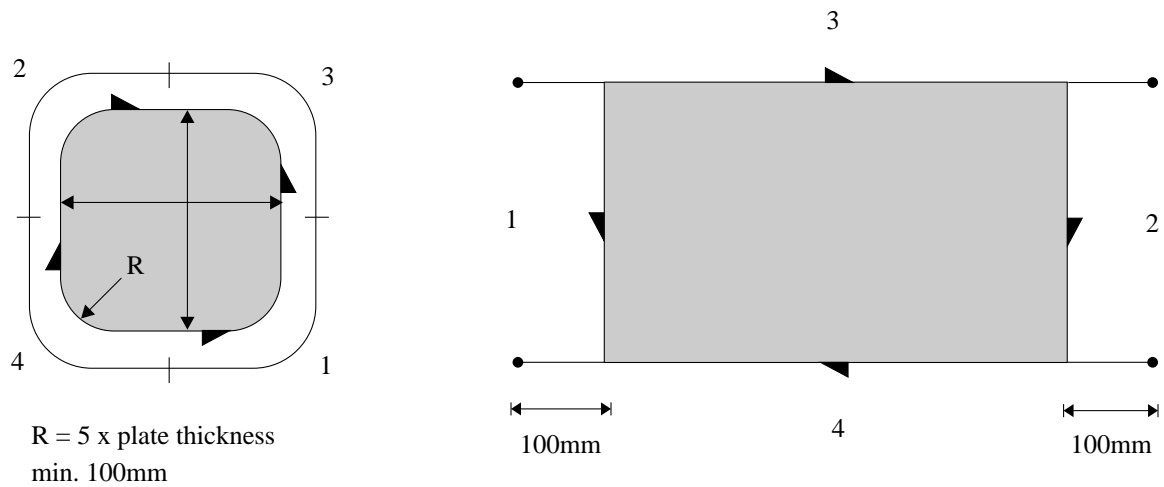

Fig 6.2 Welding sequence for inserts

Item	Standard	Limit	Remarks
Size insert	Min. 300x300mm R = 5 x thickness Circular inserts: $D_{\min}=200\text{mm}$	Min. 200x200mm Min R = 100 mm	
Material grade	Same as original or higher		See Section 4.
Edge Preparation	As for new construction		In case of non compliance increase the amount of NDE
Welding sequence	See fig.6.2 Weld sequence is 1 → 2 → 3 → 4		For primary members sequence 1 and 2 transverse to the main stress direction
Alignment	As for new construction		
Weld finish	IACS guide for inspection of ship hull welds (ref. 10)		
NDE	IACS guide (ref. 10)		

6.3 Doublers on plating

Local doublers are normally only allowed as temporary repairs, except as original compensation for openings, within the main hull structure.

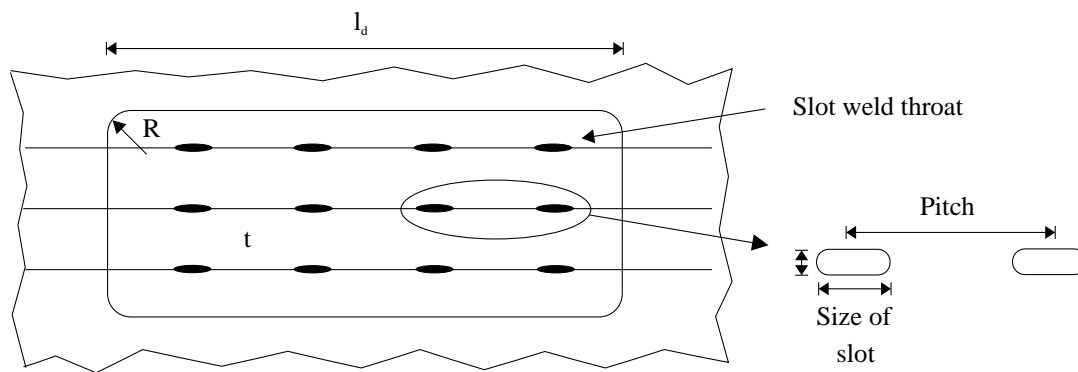

Fig. 6.3 Doublers on plates

Item	Standard	Limit	Remarks
Existing plating		General: $t \geq 5 \text{ mm}$	For areas where existing plating is less than 5mm plating a permanent repair by insert is to be carried out.
Extent/size	Rounded off corners.	min 300x300mm $R \geq 50\text{mm}$	
Thickness of doubler (t_d)	$t_d \leq t_p$ (t_p = original thickness of existing plating)	$t_d > t_p/3$	
Material grade	Same as original plate		See Section 4
Edge preparation	As for [newbuilding] new construction		Doublers welded on primary strength members: (L_e : leg length) when $t > L_e + 5\text{mm}$, the edge to be tapered (1:4)
Welding	As for [newbuilding] new construction		Welding sequence similar to insert plates.
Weld size(throat thickness)	Circumferencial and in slots: $0.6 \times t_d$		
Slot welding	Normal size of slot: $(80-100) \times 2 t_d$ Distance from doubler edge and between slots: $d \leq 15 t_d$	Max pitch between slots 200mm $d_{\text{max}} = 500\text{mm}$	For doubler extended over several supporting elements, see figure 6.3
NDE	IACS Recommendation 20 (Ref. 10)		

6.4 Renewal of internals/stiffeners

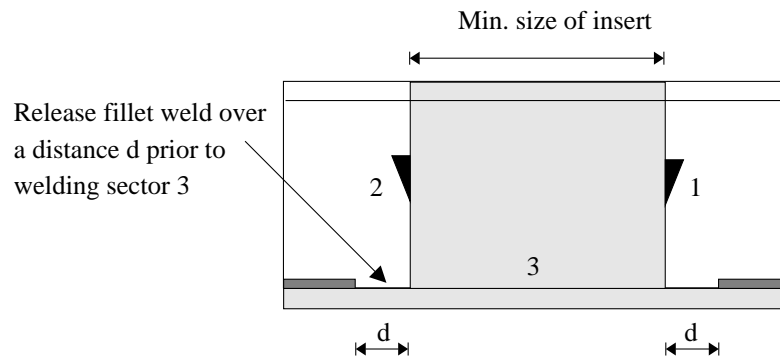

Fig 6.4 Welding sequence for inserts of stiffeners

Item	Standard	Limit	Remarks
Size insert	Min. 300 mm	Min. 200mm	
Material grade	Same as original or higher		See Section 4.
Edge Preparation	As for new construction. Fillet weld stiffener web/plate to be released over min. d = 150 mm		
Welding sequence	See fig.6.4 . Weld sequence is 1 → 2 → 3		
Alignment	As for new construction		
Weld finish	IACS guide for inspection of ship hull welds (ref. 10)		
NDE	IACS guide (ref. 10)		

6.5 Renewal of internals/stiffeners - transitions inverted angle/bulb profile

The application of the transition is allowed for secondary structural elements.

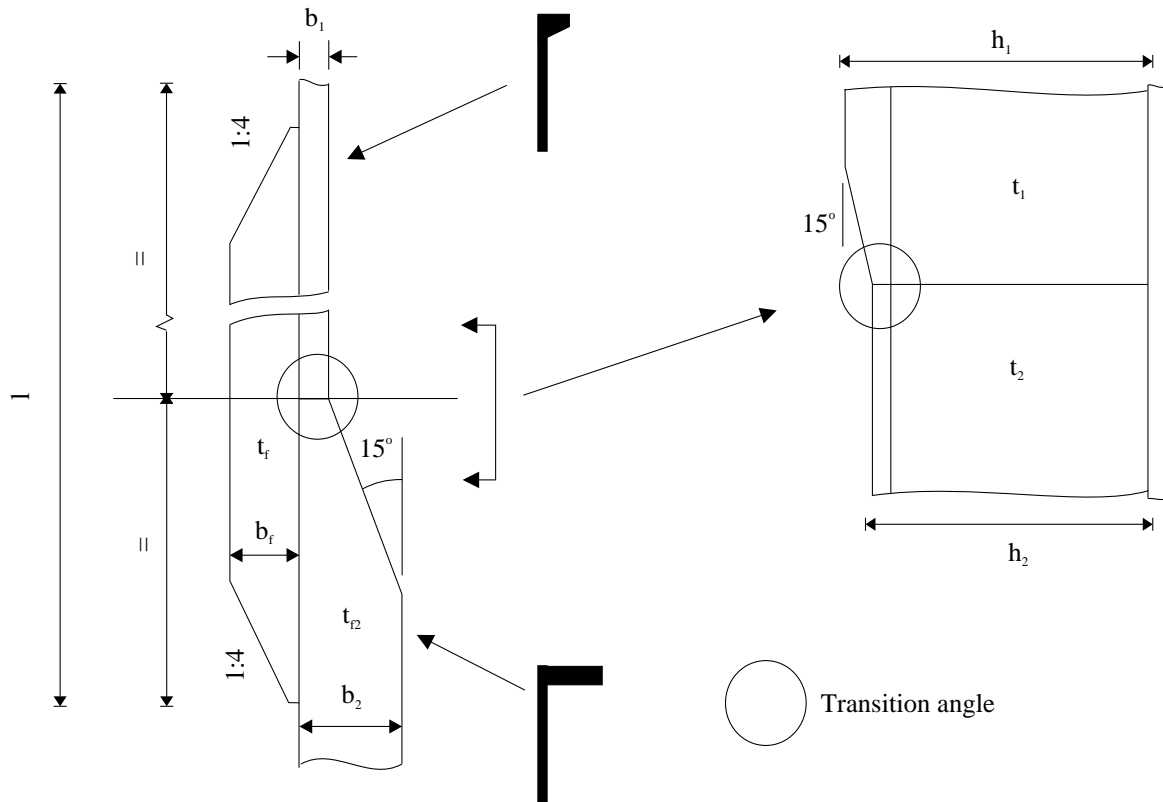

Fig. 6.5 Transition between inverted angle and bulb profile

Item	Standard	Limit	Remarks
$(h_1 - h_2)$	$\leq 0.25 \times b_1$		
$ t_1 - t_2 $	2 mm		Without tapering transition.
Transition angle	15 degrees		At any arbitrary section
Flanges	$t_f = t_{f2}$ $b_f = b_{f2}$		
Length of flatbar	$4 \times h_1$		
Material			See Section 4.

6.6 Termination of straps

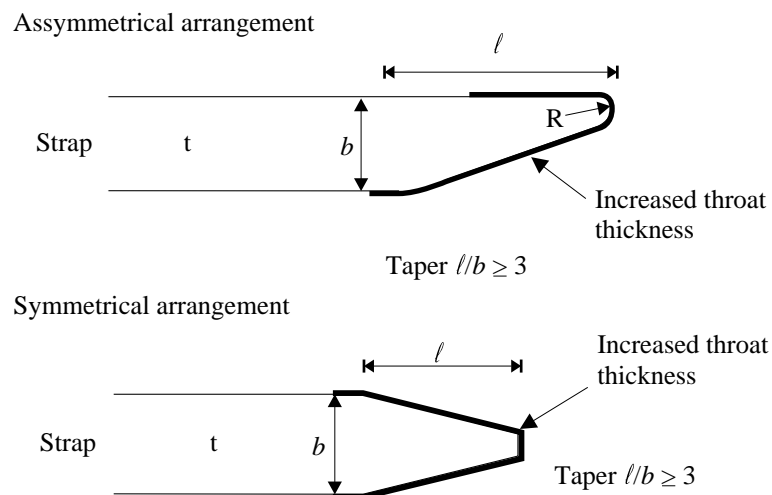

Fig. 6.6 Termination of straps

Item	Standard	Limit	Remarks
Tapering	$l/b > 3$		Special consideration to be drawn to design of strap terminations in fatigue sensitive areas.
Radius	$0.1 \times b$	min 30mm	
Material			See paragraph 2.0 General requirement to materials.
Weld size			Depending on number and function of straps. Throat thickness to be increased 15 % toward ends.
Welding	Welding sequence from middle towards the free ends		See sketch. For welding of lengths > 1000mm step welding to be applied.

6.7 Welding of pitting corrosion

NOTES:

Shallow pits may be filled by applying coating or pit filler. Pits can be defined as shallow when their depth is less than 1/3 of the original plate thickness.

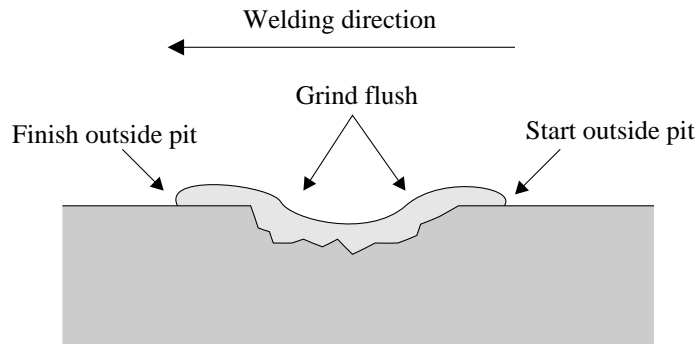

Fig. 6.7 Welding of pits

Item	Standard	Limit	Remarks
Extent/depth	Pits/grooves are to be welded flush with the original surface.	If deep pits or grooves are clustered together or remaining thickness is less than 6 mm, the plate should be renewed.	See also IACS Recommendation 12 (Ref.9)
Cleaning	Heavy rust to be removed		
Pre-Heating	See Table 5.1	Required when ambient temperature < 5°C	Always use propane torch or similar to remove any moisture
Welding sequence	Reverse direction for each layer		See also IACS guide no. 12
Weld finish	IACS guide for inspection of ship hull welds (ref. 10)		
NDE	IACS guide (ref. 10)	Min. 10% extent	Preferably MPI

Reference is made to TSCF Guidelines, Ref. 2 & 3.

6.8 Welding repairs for cracks

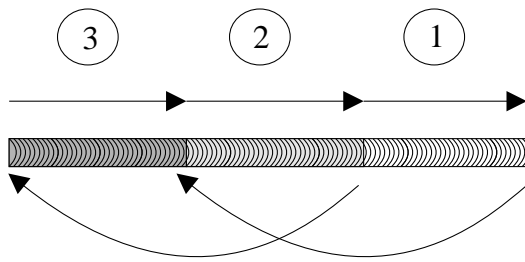

Fig. 6.8.a Step back technique

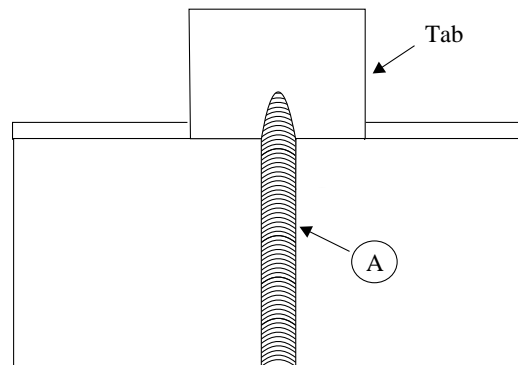

Fig 6.8.b End crack termination

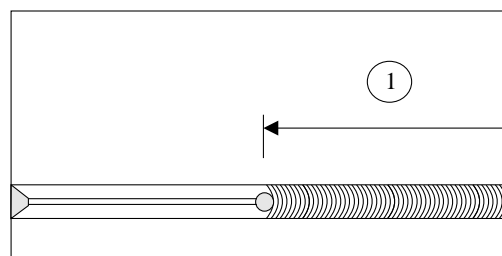
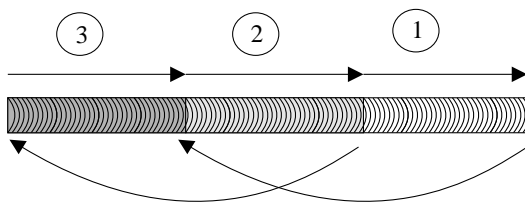

Fig 6.8.c Welding sequence for cracks with length less than 300 mm

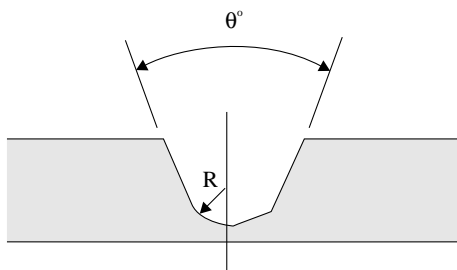

Fig. 6.8.d Groove preparation
(U-groove left and V-groove right)

Item	Standard	Limit	Remarks
Groove preparation	$\theta=45-60^\circ$ $r=5\text{ mm}$		For through plate cracks as for newbuilding. Else see fig 6.9.d
Termination	Termination to have slope 1:3		For cracks ending on edges weld to be terminated on a tab see Fig 6.9.b
Extent	On plate max. 400 mm length. Vee out 50 mm past end of crack	On plate max 500 mm. Linear crack, not branched	
Welding sequence	See fig 6.9.c for sequence and direction	For cracks longer than 300 mm step-back technique should be used Fig 6.9.a	Always use low hydrogen welding consumables
Weld finish	IACS guide for inspection of ship hull welds (ref. 10)		
NDE	IACS guide (ref.10)	100 % MP or PE of groove	100 % surface crack detection + UE or RE for butt joints

6.9 Grinding of shallow cracks

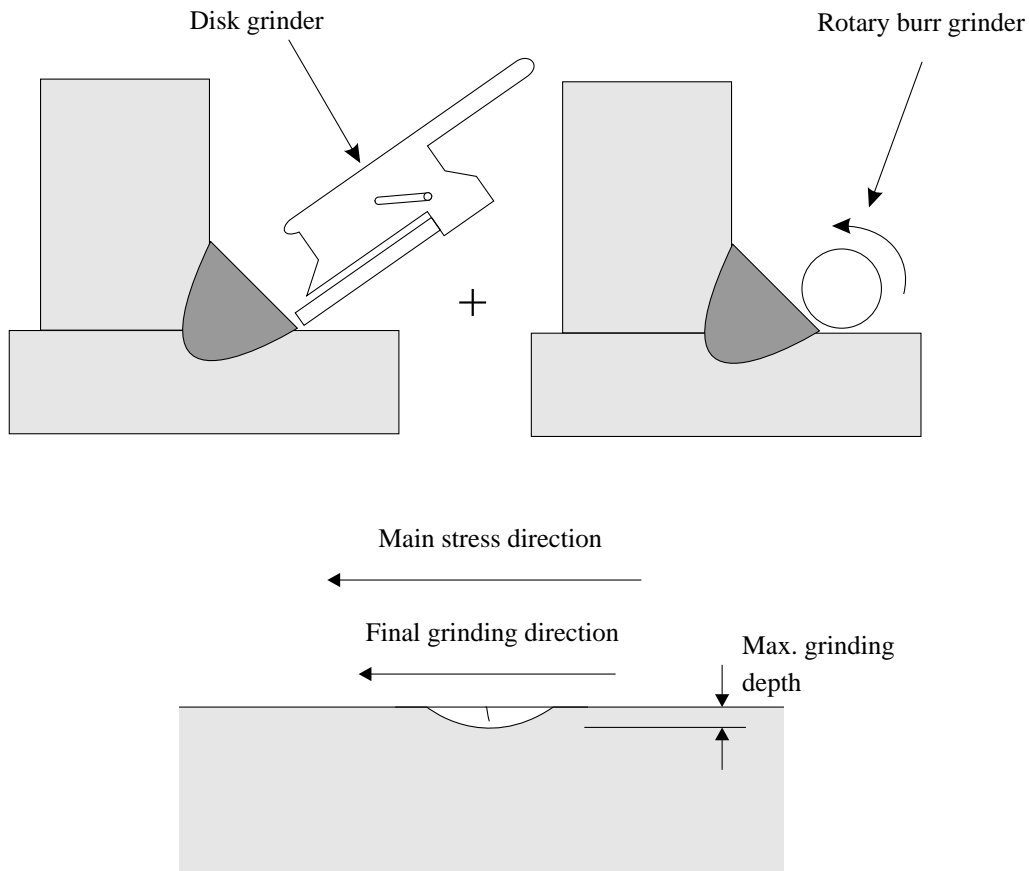

Fig 6.9 Grinding

Item	Standard	Limit	Remarks
Extent	For short cracks only max. 4 t t = Plate thickness	Max. length 100 mm	See also IACS recommendation 12, (ref. 9)
Grinding direction	Final grinding microgrooves parallel to main stress direction		Grinding always to be finished by a rotating burr and not a disk grinder
Grinding depth	Max. 0.2 t t = Plate thickness		Always smooth transition
NDE	IACS guide for inspection of ship hull welds (ref. 10)		100 % MPI